

**Sabbatical Leave Report**

**Prepared by**

**Scott Alan Guth  
Mathematics Department  
Mt. San Antonio College**

**January 8, 2001**

## Table of Contents

Statement of Proposed Sabbatical Activities .....	1
Project Timeline .....	3
Statement of Purpose .....	5
Overview .....	7
Table listing URL's of Web Pages Developed .....	10
Example LiveMath Document with Comments .....	11
Personal Experiences .....	13
Conclusion – How Does the LiveMath Web Site Help the College ....	14
Appendix – LiveMath Tutorials .....	16

## Statement of Proposed Sabbatical Activities

### I. Introduction

During the Spring Semester of 2000 I am proposing to add comprehensive Computer Algebra System (CAS) capabilities to the Mathematics Department web site, which will be available for student use.

I am the developer of the math department's website ([www.mtsac.edu/math](http://www.mtsac.edu/math)). The site currently serves Mt. SAC's mathematics instructors by offering schedules, phone numbers, and office locations of all 26 full-time instructors, course outlines for each mathematics course offered at Mt. SAC, and math department meeting minutes.

Additionally, the site provides links to sites which are of interest to mathematics students. The project which I am proposing will make the mathematics web site highly useful to students in Algebra and Calculus.

Computer Algebra Systems are becoming quite important in mathematics. All of Mt. SAC's calculus classes have a required computer algebra component. Computer algebra systems are very powerful tools for graphing curves and surfaces, manipulating mathematical expressions, and performing complex numerical calculations. They are quite expensive as well – the math department's most powerful program, Maple, costs around \$800 for an individual license.

My goal for this site is to provide a free, online, computer algebra system for Mt. SAC mathematics students, which will be available to them anywhere that there is an Internet capable computer. I will use LiveMath by Theorist Interactive to develop a series of web pages which will benefit students in Algebra and Calculus. LiveMath is a computer algebra system whose documents can be saved in HTML (web page) format – the most amazing part of this is the fact that these web pages are *interactive*. As I create and post a web page on quadratic functions, students in any way they like can alter any examples used on the page. As students change the equations, all results based on these equations change instantaneously. In this sense, the web page becomes a web page for studying all quadratics, not just the few provided by me. The value in this is that students learn how the parameters in an algebraic expression affect results dynamically.

To interact with these pages, students will need an Internet capable computer (available in the math department's computer labs if not available at home), and the Netscape browser (also available for free). The math department has already purchased LiveMath, and this is the only expense to be incurred under this project.

Initially, I plan to create pages that primarily focus on graphical interpretations of mathematical relationships in Algebra and Calculus.

In Algebra, the website will include pages that focus on:

1. Linear Functions and their Graphs.
2. Linear Inequalities and their Graphs.
3. Quadratic Functions and their Graphs.
4. The Relation between Roots, Factors, and Intercepts in Polynomial Functions.
5. Graphical Approach to Polynomial and Rational Inequalities.
6. Exponential and Logarithmic Functions and their Graphs
7. Conic Sections

In Calculus, I would like to focus on, especially, the third semester of Calculus: Math 280. I have chosen Math 280 because this class has a great deal of three-dimensional graphing, which is exceptionally difficult for students.

The web pages for Math 280 will include:

1. Two Dimensional Parametric Curves & Vector-Valued Functions
2. Three Dimensional Parametric Curves & Vector-Valued Functions
3. Surfaces in Space:  $z = f(x,y)$ ,  $x = g(y,z)$ ,  $y = h(x,z)$ .
4. Parametric Surfaces.
5. Vector Fields in 2 and 3 Dimensions (I'm not sure if LiveMath supports this type of plot)!
6. Combining multiple plots in 2 and 3 dimensions.

The final component of my project will be promotion of the web site. I plan to get explicit references to this site in major Internet search engines, such as Yahoo, Excite, and Alta Vista. I have had experience in this through other sites I have developed (my HP48GX page at [www.mtsac.edu/~sguth/hp48prog.html](http://www.mtsac.edu/~sguth/hp48prog.html), and a commercial site for a family member, [www.janegray.com](http://www.janegray.com)). Additionally, I plan to promote this site by posting notices in the math classrooms at Mt. SAC.

I am familiar with the use of LiveMath. LiveMath is a program that is nearly ten years old – it used to be called “Theorist,” and I was given an evaluation copy around 6 years ago with which I spent considerable time. Theorist/ LiveMath has always been a cutting edge program for math education, but only recently has implemented its powerful Internet capability. My copy is several years old, so I am not personally familiar with all of its new features. I am, however, sure that all of the components of my project are all possible, because I have seen example web pages posted on Maple’s “CyberMath” web site at [www.maplesoft.com](http://www.maplesoft.com). As of November 23, 1998, I have not yet received the copy of LiveMath ordered by our math department, so any additional capabilities are yet to be discovered by me. It is very possible that additional applications will be implemented on my web site (especially with regard to algebraic – non-graphical – applications).



## II. Project Timeline

Activity	Time	Dates
• Familiarization of LiveMath	2 Weeks	1/10 - 1/23
• Development of Web Pages – Intermediate Algebra		
• Linear Functions and their Graphs	1 Week	1/24 - 1/30
• Linear Inequalities and their Graphs	1 Week	1/31 - 2/6
• Quadratic Functions and their Graphs	1 Week	2/7 - 2/13
• The Relationship between Roots, Factors, and Intercepts in Polynomial Functions	1 Week	2/14 - 2/20
• Graphical Approach to Polynomial and Rational Inequalities	1 Week	2/21 - 2/27
• Exponential and Logarithmic Functions and their Graphs	1 Week	2/28 - 3/5
• Conic Sections	1 Week	3/6 - 3/12
• Development of Web Pages – Calculus		
• Two Dimensional Parametric Curves & Vector-Valued Functions	1 Week	3/13 - 3/19
• Three Dimensional Parametric Curves & Vector-Valued Functions	1 Week	3/20 - 3/26
• Surfaces in Space – Cartesian Coordinates.	1 Week	3/27 - 4/2
• Surfaces in Space – Cylindrical Coordinates	1 Week	4/10 - 4/16
• Surfaces in Space – Spherical Coordinates	1 Week	4/17 - 4/23
• Parametric Surfaces in 3 Dimensions	1 Week	4/24 - 4/30
• Investigate & Possibly Implement Vector Fields in 2 and 3 Dimensions (I'm not sure if LiveMath supports this type of plot)!	1 Week	5/1 - 5/7
• Combining multiple plots in 2 and 3 dimensions	1 Week	5/8 - 5/14
• Promotion of Web Site on Internet & at Mt. SAC (Easy to Initiate – but will take at least a month for site to finally appear in Internet search engines)	1 Week	5/15 - 5/21

(In the timeline above, it is assumed that Spring break is from 4/3/00 to 4/9/00).

### III. Benefit of the Proposed Activity to Mt. SAC, the Math Department & Mathematics Students

This project has the potential to impact any student in any of nearly 60 sections of Intermediate Algebra and Calculus offered each semester at Mt. SAC. For most students in algebra, computer algebra systems are rarely encountered and difficult to use. Students who can afford graphing calculators (cost: approximately \$100) experience a small sample of what computer algebra systems can do. This project will give students access to a program of much higher quality than a graphing calculator. The web site will be available at no cost, even for students who do not own a computer, given the availability of Internet capable computers in the Mt. SAC mathematics computer labs. I believe that the Math Department will adopt this web site as an integral part of its program. Finally, I believe that the site will be quite popular, and will help the college as it strives for the goal of technological leadership among community colleges.

## Statement of Purpose

The purpose of my sabbatical leave was to prepare a tutorial web-site at [math.mtsac.edu](http://math.mtsac.edu). The web-site was to use the browser plug-in called LiveMath as an interface for an online computer algebra system (CAS) and mathematics tutorial for student use over the Internet.

LiveMath is a unique computer algebra system that can be used to create interactive documents that have the ability to perform algebra and calculus operations. The author of a given LiveMath document writes a tutorial explaining the steps involved in a given mathematical procedure. The authoring process involves teaching the LiveMath document the steps involved in solving a given problem, and then supplying an example. Text explanations can be entered between steps, so that the student knows what is being done by the document. The actual programming in the document is hidden from the student. When a student views the LiveMath document, the document looks no different from a math textbook. The difference is that students may change the input values and expressions on a given LiveMath document, and all results generated from the input are updated immediately.

So the LiveMath document is an interactive one, which has the ability to explain the process of solving an infinite number of problems. Clearly, students can abuse the use of such power. When students begin using LiveMath, they are encouraged to read the online LiveMath Philosophy:

LiveMath is a wonderful tool for helping you to learn mathematics. With LiveMath, you can get explanations on solving most types of problems in Algebra, along with many Calculus applications as well — without even leaving your home! LiveMath is a FREE computer algebra system. All you need is a computer with Internet capabilities.

We at Mt. SAC are quite aware that LiveMath can be used to do your homework for you, but this will not help you perform well on tests! Please understand that LiveMath is meant to help you understand the math problems that are causing you trouble. The goal is to learn to solve such problems by yourself, *without* using LiveMath. Think of LiveMath as your electronic math tutor, and remember that **the best tutors *never* do your homework for you!**

## Overview

Most professional mathematicians today use computer algebra systems. A computer algebra system is a software application that has the ability to perform symbolic computations. Symbolic computations are different from numerical computations in that they manipulate mathematical symbols – variables, while numerical computations manipulate numbers only. A computer algebra system has the ability to solve equations symbolically, returning exact answers, while a numerical application usually returns only approximate answers.

For example, if I use Maple, one of the best computer algebra systems available, to solve the equation  $x^2 + x - 1 = 0$  for  $x$ , the program returns two exact solutions:  $\frac{-1 + \sqrt{5}}{2}$  and  $\frac{-1 - \sqrt{5}}{2}$ . If I use a numerical math program (like Matlab or MathCAD), I would get two approximate solutions: 0.6180 and  $-1.6180$ .

If I ask Maple to solve  $ax^2 + bx + c = 0$  for  $x$ , the program returns two symbolic solutions:  $\frac{-b + \sqrt{b^2 - 4ac}}{2a}$  and  $\frac{-b - \sqrt{b^2 - 4ac}}{2a}$ . A numerical math program would not solve such a problem at all, since the solutions are not numbers. Both numerical and symbolic programs usually include graphing of mathematical relationships in two or three dimensions.

In algebra and calculus, students do much work on symbolic and numerical computations, as well as graphing. Calculators can do most numerical computations that they need, and graphing calculators can do two-dimensional graphing. For symbolic calculations and three-dimensional graphing, most students must use the computer algebra systems provided for student use in mathematics computer labs.

The problem with most computer algebra systems is that they take input from the user, perform calculations, and then display results with no explanation of how the calculations are done. This can be helpful for students in checking their work, or in solving problems that are

beyond their skills. (Instructors commonly give problems that are quite difficult to solve by hand for computer lab assignments. The point is usually is for students to learn to design the mathematical model which describes some application, enter the model into the computer, and then have the computer actually do the computing to solve the problem). But for actually teaching a student the process of solving the problem, the computer is usually rather useless.

Most tutorial programs, which teach the process of solving mathematical problems, are quite poor and unimaginative. There are a few exceptions to this, but these exceptions tend to be quite expensive.

Then there is LiveMath. LiveMath is a flexible computer algebra system with a document editor that has built in symbolic and numerical capabilities. In one sense, LiveMath's symbolic capabilities are quite primitive (compared to Maple, for example) – the author of a LiveMath document often must teach LiveMath the steps required in solving the problem at hand (an often daunting task!). This weakness has a benefit though. Since problems are done step by step according to the design of the author, students have the opportunity to see all of the computations required in solving a given problem!

So LiveMath has the ability to create documents which show the steps involved in solving a problem. Even better is the fact that LiveMath acts like a spreadsheet. After a document has been created, anyone viewing the document from a computer can change the example problem to a different problem of the same type! After this, LiveMath updates the rest of the document as it solves and displays the steps in solving the new example. So the pages are totally interactive, and there is no limit to the number of problems that LiveMath can solve. The best thing about all of this is that LiveMath documents can be imbedded into web pages and viewed online with either Internet Explorer or Netscape! Those who wish to view these pages need only download a free browser plug-in from the LiveMath web-site, and they are ready to do interactive computer algebra online and FREE.

For my sabbatical, I developed tutorial web pages for Algebra and Calculus students using LiveMath. I chose to focus mostly on applications which involve some graphing because so many algebra students have trouble graphing and also because three-dimensional graphing creates problems for many students in calculus.

The actual development process was always a challenge. As mentioned, LiveMath is rather primitive in terms of its symbolic capabilities. With most of the pages developed I was in the position of trying to decide how to best teach my LiveMath documents to solve whatever problem was the subject of the current web page. This was often quite difficult, and sometimes I was not entirely happy with my best solution of the problem, but regardless, I pressed on.

On the following page is a table that lists the topics and corresponding Internet addresses for the LiveMath web pages developed during my sabbatical leave. Alternately, the reader may choose to browse to <http://math.mtsac.edu> to view the LiveMath pages first-hand. It should be noted that the LiveMath plug-in is required in order to view the pages. Instructions for attaining and installing this plug-in are given on the web-site. Many topics are covered on the web-site that are not listed on the following table – I developed these as well, but through Title V funding.

<b>Topics in Algebra</b>	<b>Internet Address</b>
Linear Functions and their Graphs	<a href="http://math.mtsac.edu/LiveMath/algebra/solving/lineareq2.html">math.mtsac.edu/LiveMath/algebra/solving/lineareq2.html</a> <a href="http://math.mtsac.edu/LiveMath/algebra/graphing/lines.html">math.mtsac.edu/LiveMath/algebra/graphing/lines.html</a> <a href="http://math.mtsac.edu/LiveMath/algebra/graphing/twopoints.html">math.mtsac.edu/LiveMath/algebra/graphing/twopoints.html</a>
Linear Inequalities and their Graphs	<a href="http://math.mtsac.edu/LiveMath/algebra/inequalities/linearinequalities.html">math.mtsac.edu/LiveMath/algebra/inequalities/linearinequalities.html</a> <a href="http://math.mtsac.edu/LiveMath/algebra/inequalities/lingrea.html">math.mtsac.edu/LiveMath/algebra/inequalities/lingrea.html</a> <a href="http://math.mtsac.edu/LiveMath/algebra/inequalities/lingrea=.html">math.mtsac.edu/LiveMath/algebra/inequalities/lingrea=.html</a> <a href="http://math.mtsac.edu/LiveMath/algebra/inequalities/linless.html">math.mtsac.edu/LiveMath/algebra/inequalities/linless.html</a> <a href="http://math.mtsac.edu/LiveMath/algebra/inequalities/linless=.html">math.mtsac.edu/LiveMath/algebra/inequalities/linless=.html</a>
Quadratic Functions and their Graphs	<a href="http://math.mtsac.edu/LiveMath/algebra/graphing/quadrat3.html">math.mtsac.edu/LiveMath/algebra/graphing/quadrat3.html</a>
The Relationship between Roots, Factors, & Intercepts in Polynomial Functions	<a href="http://math.mtsac.edu/LiveMath/algebra/solving/rootsintercepts.html">math.mtsac.edu/LiveMath/algebra/solving/rootsintercepts.html</a>
Graphical Approach to Polynomial and Rational Inequalities	<a href="http://math.mtsac.edu/LiveMath/algebra/inequalities/polygt.html">math.mtsac.edu/LiveMath/algebra/inequalities/polygt.html</a> <a href="http://math.mtsac.edu/LiveMath/algebra/inequalities/polyge.html">math.mtsac.edu/LiveMath/algebra/inequalities/polyge.html</a> <a href="http://math.mtsac.edu/LiveMath/algebra/inequalities/polylt.html">math.mtsac.edu/LiveMath/algebra/inequalities/polylt.html</a> <a href="http://math.mtsac.edu/LiveMath/algebra/inequalities/polyle.html">math.mtsac.edu/LiveMath/algebra/inequalities/polyle.html</a> <a href="http://math.mtsac.edu/LiveMath/algebra/inequalities/ratneqgt.html">math.mtsac.edu/LiveMath/algebra/inequalities/ratneqgt.html</a> <a href="http://math.mtsac.edu/LiveMath/algebra/inequalities/ratneqge.html">math.mtsac.edu/LiveMath/algebra/inequalities/ratneqge.html</a> <a href="http://math.mtsac.edu/LiveMath/algebra/inequalities/ratneqlt.html">math.mtsac.edu/LiveMath/algebra/inequalities/ratneqlt.html</a> <a href="http://math.mtsac.edu/LiveMath/algebra/inequalities/ratneqle.html">math.mtsac.edu/LiveMath/algebra/inequalities/ratneqle.html</a>
Exponential and Logarithmic Functions and their Graphs	<a href="http://math.mtsac.edu/LiveMath/algebra/graphing/plottingexponentials.html">math.mtsac.edu/LiveMath/algebra/graphing/plottingexponentials.html</a> <a href="http://math.mtsac.edu/LiveMath/algebra/graphing/plottinglogarithms.html">math.mtsac.edu/LiveMath/algebra/graphing/plottinglogarithms.html</a>
Conic Sections	<a href="http://math.mtsac.edu/LiveMath/algebra/graphing/parabcon.html">math.mtsac.edu/LiveMath/algebra/graphing/parabcon.html</a> <a href="http://math.mtsac.edu/LiveMath/algebra/graphing/consec.html">math.mtsac.edu/LiveMath/algebra/graphing/consec.html</a>
<b>Topics in Calculus</b>	<b>Internet Address</b>
Two Dimensional Parametric	<a href="http://math.mtsac.edu/LiveMath/calculus/math180/param2d.html">math.mtsac.edu/LiveMath/calculus/math180/param2d.html</a>
Two Dimensional Curves & Vector-Valued Functions	<a href="http://math.mtsac.edu/LiveMath/calculus/math280/VectorValuedFunctions/vvf2d2.html">math.mtsac.edu/LiveMath/calculus/math280/VectorValuedFunctions/vvf2d2.html</a>
Three Dimensional Parametric Curves & Vector-Valued Functions	<a href="http://math.mtsac.edu/LiveMath/calculus/math280/VectorValuedFunctions/spacecurve.html">math.mtsac.edu/LiveMath/calculus/math280/VectorValuedFunctions/spacecurve.html</a> <a href="http://math.mtsac.edu/LiveMath/calculus/math280/VectorValuedFunctions/spacecurvevf.html">math.mtsac.edu/LiveMath/calculus/math280/VectorValuedFunctions/spacecurvevf.html</a> <a href="http://math.mtsac.edu/LiveMath/calculus/math280/VectorValuedFunctions/vvf3dveloc.html">math.mtsac.edu/LiveMath/calculus/math280/VectorValuedFunctions/vvf3dveloc.html</a> <a href="http://math.mtsac.edu/LiveMath/calculus/math280/VectorValuedFunctions/vvf3accel.html">math.mtsac.edu/LiveMath/calculus/math280/VectorValuedFunctions/vvf3accel.html</a> <a href="http://math.mtsac.edu/LiveMath/calculus/math280/VectorValuedFunctions/vvf3tn.html">math.mtsac.edu/LiveMath/calculus/math280/VectorValuedFunctions/vvf3tn.html</a> <a href="http://math.mtsac.edu/LiveMath/calculus/math280/VectorValuedFunctions/vvf3tmb.html">math.mtsac.edu/LiveMath/calculus/math280/VectorValuedFunctions/vvf3tmb.html</a>
The topics below are integrated in the web pages listed to the right.	<a href="http://math.mtsac.edu/LiveMath/calculus/math280/RectangularRegion/rectangular.html">math.mtsac.edu/LiveMath/calculus/math280/RectangularRegion/rectangular.html</a> <a href="http://math.mtsac.edu/LiveMath/calculus/math280/HorizontallySimple/horzsimp.html">math.mtsac.edu/LiveMath/calculus/math280/HorizontallySimple/horzsimp.html</a> <a href="http://math.mtsac.edu/LiveMath/calculus/math280/VerticallySimple/vertsimp.html">math.mtsac.edu/LiveMath/calculus/math280/VerticallySimple/vertsimp.html</a> <a href="http://math.mtsac.edu/LiveMath/calculus/math280/ParametricSurfaces/param3d.html">math.mtsac.edu/LiveMath/calculus/math280/ParametricSurfaces/param3d.html</a> <a href="http://math.mtsac.edu/LiveMath/calculus/math280/ImplicitSurface/implicitquadratic.html">math.mtsac.edu/LiveMath/calculus/math280/ImplicitSurface/implicitquadratic.html</a> <a href="http://math.mtsac.edu/LiveMath/calculus/math280/RectangularRegion/rectangulartanplane.html">math.mtsac.edu/LiveMath/calculus/math280/RectangularRegion/rectangulartanplane.html</a> <a href="http://math.mtsac.edu/LiveMath/calculus/math280/HorizontallySimple/horzsimptanplane.html">math.mtsac.edu/LiveMath/calculus/math280/HorizontallySimple/horzsimptanplane.html</a> <a href="http://math.mtsac.edu/LiveMath/calculus/math280/VerticallySimple/vertsimptanplane.html">math.mtsac.edu/LiveMath/calculus/math280/VerticallySimple/vertsimptanplane.html</a> <a href="http://math.mtsac.edu/LiveMath/calculus/math280/ParametricSurfaces/param3dtanpl.html">math.mtsac.edu/LiveMath/calculus/math280/ParametricSurfaces/param3dtanpl.html</a> <a href="http://math.mtsac.edu/LiveMath/calculus/math280/ImplicitSurface/implicittanpl.html">math.mtsac.edu/LiveMath/calculus/math280/ImplicitSurface/implicittanpl.html</a> <a href="http://math.mtsac.edu/LiveMath/calculus/math280/RectangularRegion/rectangulargrad.html">math.mtsac.edu/LiveMath/calculus/math280/RectangularRegion/rectangulargrad.html</a> <a href="http://math.mtsac.edu/LiveMath/calculus/math280/HorizontallySimple/horzsimpgrad.html">math.mtsac.edu/LiveMath/calculus/math280/HorizontallySimple/horzsimpgrad.html</a> <a href="http://math.mtsac.edu/LiveMath/calculus/math280/VerticallySimple/vertsimpgrad.html">math.mtsac.edu/LiveMath/calculus/math280/VerticallySimple/vertsimpgrad.html</a> <a href="http://math.mtsac.edu/LiveMath/calculus/math280/ImplicitSurface/implicitgrad.html">math.mtsac.edu/LiveMath/calculus/math280/ImplicitSurface/implicitgrad.html</a> <a href="http://math.mtsac.edu/LiveMath/calculus/math280/RectangularRegion/rectangularflux.html">math.mtsac.edu/LiveMath/calculus/math280/RectangularRegion/rectangularflux.html</a> <a href="http://math.mtsac.edu/LiveMath/calculus/math280/HorizontallySimple/horzsimpflux.html">math.mtsac.edu/LiveMath/calculus/math280/HorizontallySimple/horzsimpflux.html</a> <a href="http://math.mtsac.edu/LiveMath/calculus/math280/VerticallySimple/vertsimpflux.html">math.mtsac.edu/LiveMath/calculus/math280/VerticallySimple/vertsimpflux.html</a> <a href="http://math.mtsac.edu/LiveMath/calculus/math280/ParametricSurfaces/param3dflux.html">math.mtsac.edu/LiveMath/calculus/math280/ParametricSurfaces/param3dflux.html</a> <a href="http://math.mtsac.edu/LiveMath/calculus/math280/ParametricSurfaces/param3dflux.html">math.mtsac.edu/LiveMath/calculus/math280/ParametricSurfaces/param3dflux.html</a>
Surfaces in Space – Cartesian Coordinates.	
Parametric Surfaces in 3 Dimensions	
Vector Fields in 2 and 3 Dimensions	
Combining multiple plots in 3 dimensions	
Surfaces in Space – Cylindrical Coordinates	<a href="http://math.mtsac.edu/LiveMath/calculus/math280/cylindrical.html">math.mtsac.edu/LiveMath/calculus/math280/cylindrical.html</a>
Surfaces in Space – Spherical Coordinates	<a href="http://math.mtsac.edu/LiveMath/calculus/math280/spherical.html">math.mtsac.edu/LiveMath/calculus/math280/spherical.html</a>
Combining Multiple Plots in 2 dimensions	<a href="http://math.mtsac.edu/LiveMath/calculus/math180/plotter.html">math.mtsac.edu/LiveMath/calculus/math180/plotter.html</a>



Below is an example of a LiveMath web page, with comments.

### Solving a 2x2 Linear System by Elimination

Please enter your 2x2 linear system below.

$$\text{system} = \begin{pmatrix} [2x - 3y = 3] \\ [3x + 4y = 6] \end{pmatrix}$$

The user can change this system of equations to any other system of interest.

The solution to the system is the intersection of the two lines plotted below. If you don't see two lines intersecting, then there is either infinitely many solutions, or no solutions.

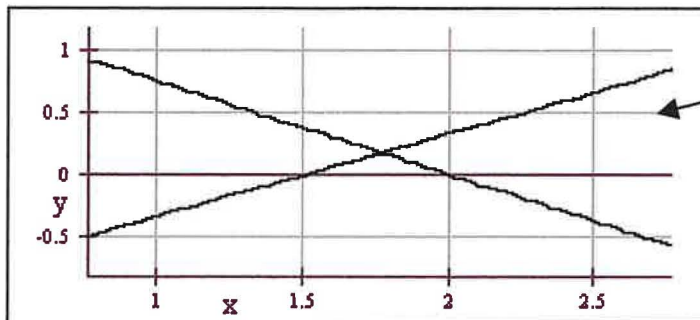

After entering a desired system, this graph updates to reflect changes made by the user.

We now proceed to attempt to solve the system by elimination. In some cases, the computer may do this slightly differently than you would. Try to follow

Our first step is to attempt to make the x-coefficient = 1 in the first equation by dividing through by the x-coeff. in that equation (we swap equations then divide if this x-coeff. is zero).

$$\text{system} = \begin{pmatrix} [x - \frac{3}{2}y = \frac{3}{2}] \\ [3x + 4y = 6] \end{pmatrix}$$

Additionally, each of these results is updated according to user input.

Next we eliminate the x-coefficient in the second equation (if it is not already zero). To do this, we multiply the first equation by the negative of the x-coefficient in the second equation, then add the equations together.

$$\text{system} = \begin{pmatrix} [x - \frac{3}{2}y = \frac{3}{2}] \\ [\frac{17}{2}y = \frac{3}{2}] \end{pmatrix}$$

Now we want to make the y-coefficient = 1 in the second equation by dividing through by that y-coeff. (If this coefficient is zero, we won't do anything).

$$\text{system} = \begin{pmatrix} [x - \frac{3}{2}y = \frac{3}{2}] \\ [y = \frac{3}{17}] \end{pmatrix}$$

And finally we eliminate the y-coefficient in the first equation. This should solve the system. If either of the final equations is contradictory (reading  $0 = 1$  or some other such nonsense), then there is no solution. If either equation has vanished (becoming  $0 = 0$ ) then there are infinitely many solutions (provided that the first equation is consistent).

$$\text{system} = \begin{pmatrix} [x = \frac{30}{17}] \\ [y = \frac{3}{17}] \end{pmatrix}$$

In addition to the mathematical content, there are also pages explaining how to upload & install the LiveMath plugin, how to use LiveMath, and how to enter mathematical expressions from the keyboard.

I am already promoting the LiveMath web-site at <http://math.mtsac.edu>. When more of my Title V content goes online, I plan to have posters made to make students aware of the web-site, which I will post in classrooms and other locations in building 26 and possibly around campus. I had originally planned to advertise the site on various Internet search engines, but decided that it would be best to restrict traffic to Mt. SAC students primarily, as they are the students that I am here to serve.

Using the Mathematics Department's staff development funds through Title V, I have conducted two sessions for training mathematics faculty to use the LiveMath web pages, so that they can refer students to them, and help students if they have difficulties.

## Personal Experiences

- LiveMath is much more primitive than I had originally expected. Tutorials that I thought would only require a few hours usually took several days. I found myself “teaching” LiveMath hundreds of new rules for working with mathematical expressions. I learned that creating a computer algebra system is an extremely difficult task (one that most mathematicians take for granted).
- I had the opportunity to be deeply frustrated by many software bugs and limitations that were beyond my control. For most of these, I was able to find a workaround. A few remain unsolved, and I simply hope that future revisions of the software will bring a solution.
- Over the five months that I worked with LiveMath, I learned a great deal on the use of the product itself. Many of the tutorials written by me at the beginning of the semester were rewritten at the end because I learned a better method. Others I plan to improve still, as time permits.
- I had many opportunities to work with the college’s excellent webmaster, Mike Fernandez. Mike tolerated a great deal of email & voicemail from me, asking for help with web site and HTML issues.
- Overall, I have learned a great deal with regard to LiveMath and to web site development in general. These experiences will help me stay on the forefront of technology in mathematics education. This is especially important as many of the students I work with (in Calculus, Differential Equations, and Linear Algebra especially) have technical majors that involve computer programming.

## Conclusion – How Does the LiveMath Web Site Help the College?

Much more work needs to be done, before the LiveMath site is done! With Title V funding, I plan to complete tutorials for nearly every subject covered in Intermediate Algebra at Mt. SAC. This will keep me busy for nearly a year, but the result should greatly help interested students. At last students can get online interactive tutorials from any computer, anywhere in the world, and it's FREE!

This project has the potential to impact any student in any of nearly 60 sections of Intermediate Algebra and Calculus offered each semester at Mt. SAC. For most students in algebra, computer algebra systems are rarely encountered and difficult to use. Students who can afford graphing calculators (cost: appx. \$100) experience a small sample of what computer algebra systems can do. This project will give students access to a program of much higher quality than a graphing calculator. The web site is available at no cost, even for students who do not own a computer, given the availability of Internet capable computers in the Mt. SAC mathematics computer labs. I believe that the site will be quite popular, and will help the college as it works toward the goal of technological leadership among community colleges.

This project will be of value to the college and its students in many ways. A few of these are listed below.

- All algebra & calculus students at Mt. SAC may receive help from any Internet capable computer. This will increase student success in algebra & calculus courses at Mt. SAC.
- Students who are unable to afford costly CAS enabled graphing calculators may use this web site to perform similar computations & graphs at no cost to them.

- The online tutorial content developed through as this project may be used to enhance course content for future distance learning courses conducted by the Mt. SAC mathematics department.
- Quality online content hosted by Mt. SAC helps to establish the college as a leader in innovative technology-based education.

Appendix  
LiveMath Tutorials

## Solving Linear Equations

In this worksheet we solve linear equations graphically, then algebraically.

First, solving the equation graphically.

Please enter the left and right hand sides (LHS & RHS) of your linear equation below.

$$\text{LHS} = 13 + 7(4 - 14x) + 21 - x$$

$$\text{RHS} = 11 - 5(13 - 7x) + 22$$

On the graph below two graphs are drawn. The left hand side ( $y = \text{LHS}$ ) is plotted in red, while the right - hand side ( $y = \text{RHS}$ ) is plotted in black.

The solution of your equation is the  $x$  - coordinate of the intersection of the two graphs.

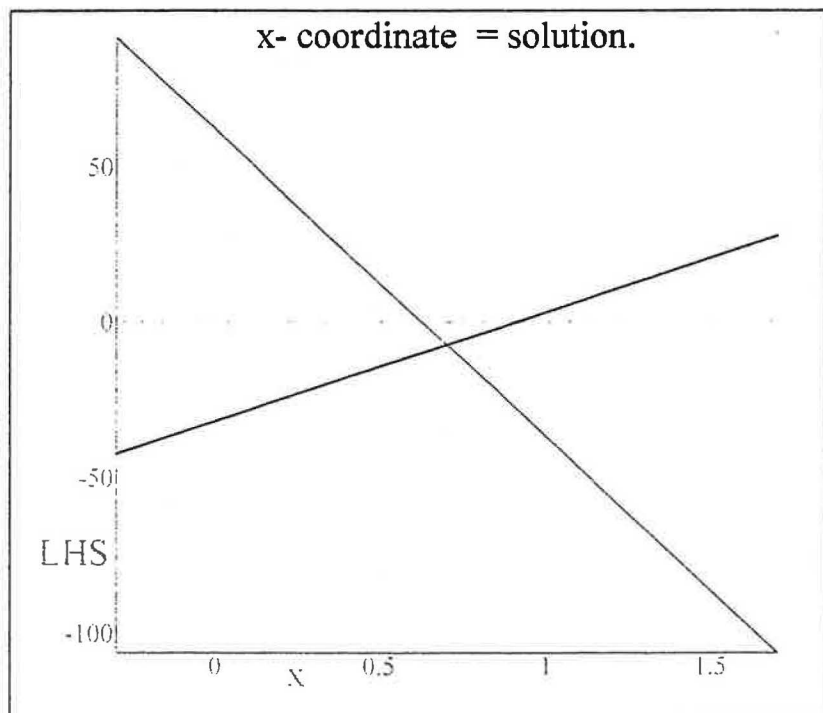

Next, the solving the equation algebraically.

The equation given by you is below.

$$7(-14x + 4) - x + 34 = -5(-7x + 13) + 33$$

First, we distribute and collect terms.

$$-99x + 62 = 35x - 32$$

Next, we move  $x$  - terms to the left, and constant terms to the right.

$$-134x + 62 = -32$$

$$-134x = -94$$

Finally, we divide both sides by the  $x$  - coefficient to obtain the solution.

$$x = \frac{47}{67}$$

Copyright July 2000 by Scott Guth  
Mt. San Antonio College



## Plotting a Line Whose Equation is in Slope - Intercept Form

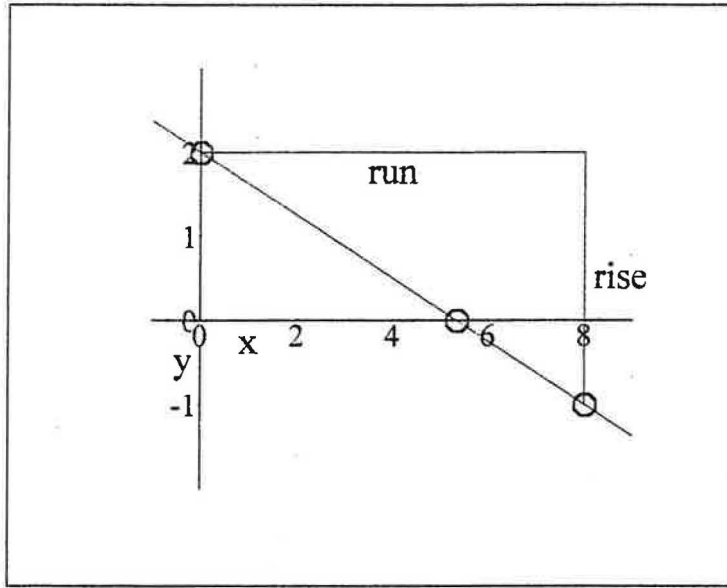

The equation of a line (non-vertical) can be written in slope-intercept form  $y = m x + b$ , where  $m$  is the slope and  $b$  is the  $y$ -intercept of the line.

Please modify the equation of the line below.

$$y = -\frac{3}{8}x + 2$$

The slope of the line you entered is:

$$m = -\frac{3}{8}$$

The slope of the line is a measure of steepness, and can be thought of as the ratio  $m = \frac{\text{rise}}{\text{run}}$ , where the rise and run are the vertical and horizontal displacements, respectively along the line as we move from an initial point to another point on the line. Whenever the slope is not a fraction, we usually write the slope as  $m = \frac{m}{1}$  so here the rise is  $m$  and the run is 1.

Using the slope you entered, the rise and run are:

$$\text{rise} = -3 \quad \text{run} = 8$$

The y-intercept is the point where the line crosses the y-axis. When the line is in slope-intercept form ( $y = m x + b$ ), the y-coordinate of the y-intercept is b.

The y-coordinate of the y-intercept for the line you entered is:  $b = 2$

Next, the x-intercept of a line is the point where the line crosses the x-axis. To find the x-intercept of a line, set  $y = 0$  in the equation of the line and solve for x. Below we find the x - intercept for the line you've entered, step-by-step.

$$y = -\frac{3}{8}x + 2$$

$$0 = -\frac{3}{8}x + 2$$

$$\frac{3}{8}x = 2$$

$$x = \frac{2}{\frac{3}{8}}$$

$$x = \frac{16}{3}$$

This solution for x (where  $y = 0$ ) is the x - intercept.

$$x_{\text{int}} = \frac{16}{3}$$

The decimal expansion of the x - intercept is below.

$$x_{\text{int}} = 5.3333$$

To actually graph the line, we start by plotting the y-intercept. Next, we move horizontally from the y-intercept a distance equal to the "run" in the slope. Now we move vertically a distance equal to the "rise" in the slope. If the "rise" is positive, go up. If the rise is negative, go down. Now you have another point on the line (which is all you need to graph the line). Plot the x-intercept, and all three points should lie on the same line. If they don't, you've made a mistake!

The graph of the line you've entered is below.

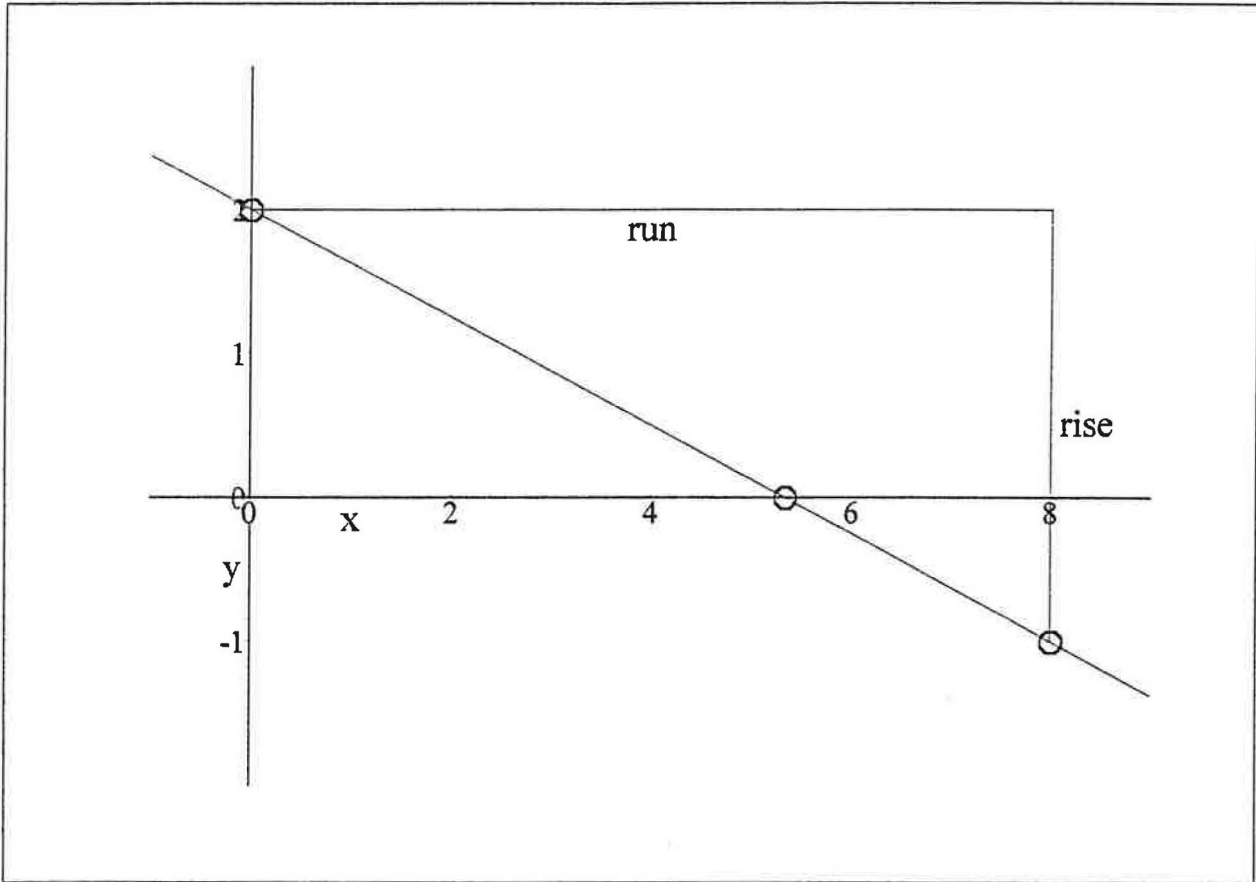

Copyright July 2000 by Scott Guth  
Mt. San Antonio College

## Finding the Equation of a Line When Given Two Points

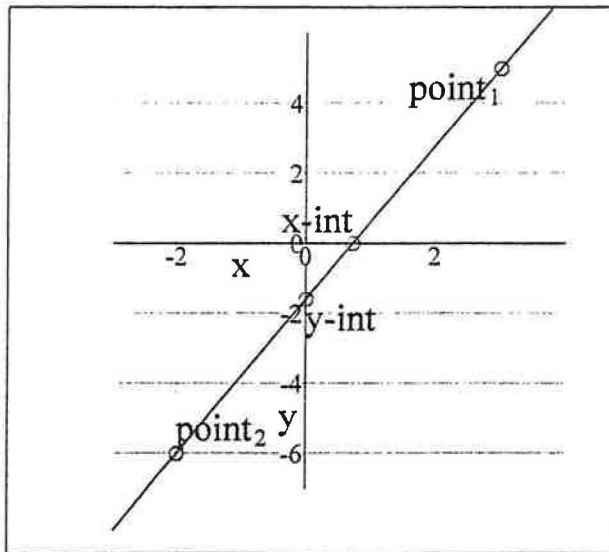

Please edit the points below.

$$\text{point}_1 = (3, 5)$$

$$\text{point}_2 = (-2, -6)$$

Below, we state the coordinates of each point separately.

$$x_1 = 3 \quad y_1 = 5$$

$$x_2 = -2 \quad y_2 = -6$$

Next, we need to compute the slope of the line.

The formula is given below.

$$m = \frac{y_2 - y_1}{x_2 - x_1}$$

And this evaluates to:

$$m = \frac{11}{5}$$

Now we use the first point and the slope to find the equation of the line in point-slope form.

$$y - y_1 = m(x - x_1)$$

$$y - 5 = \frac{11}{5}(x - 3)$$

Next, we solve for y to get slope-intercept form.

$$y = \frac{11}{5}(x - 3) + 5$$

$$y = \frac{11}{5}x - \frac{8}{5}$$

To find the y - intercept, we set  $x = 0$ ...

$$x = 0$$

$$y = -\frac{8}{5}$$

$$y_{\text{int}} = (x, y)$$

$$y_{\text{int}} = (0, -\frac{8}{5})$$

To find the x - intercept, we set  $y = 0$

$$y = 0$$

$$0 = \frac{11}{5}x - \frac{8}{5}$$

$$x = \frac{8}{11}$$

$$x_{\text{int}} = (x, y)$$

$$x_{\text{int}} = (\frac{8}{11}, 0)$$

Finally we plot the graph. Intercepts and initial points are labeled.

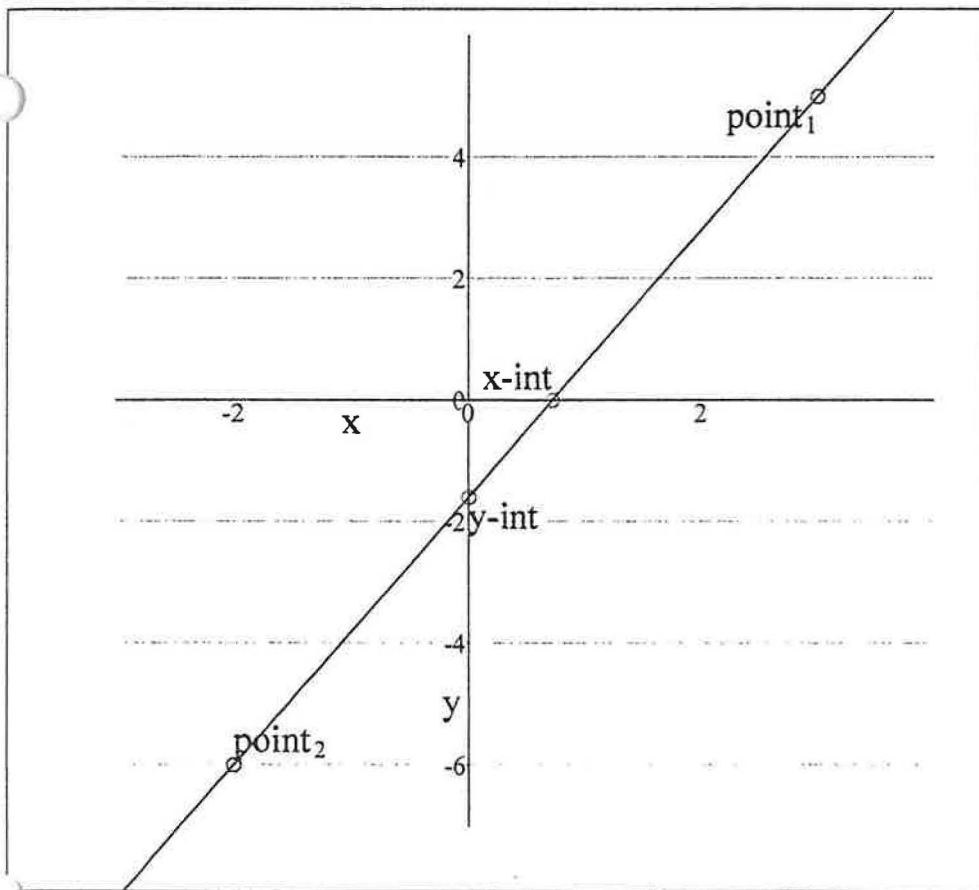

## Linear Inequalities

- Enter an absolute value inequality in the parentheses below. To enter a "less than or equal" symbol, just type  $< =$ . For "greater than or equal" type  $> =$ . To type absolute value symbols  $| ? |$ , press the vertical slash button  $|$  on your keyboard.

$$\text{Inequality} = \left( 5x + \frac{7}{3} \left[ 1 - \frac{3}{2}x \right] > 1 + \frac{7}{5} \left[ 2 + \frac{2}{3}x \right] \right)$$

$$\text{Inequality} = \left( \frac{3}{2}x + \frac{7}{3} > 1 + \frac{7}{5} \left[ 2 + \frac{2}{3}x \right] \right)$$

$$\text{Inequality} = \left( \left[ \frac{3}{2}x + \frac{7}{3} \right] - \left[ \frac{7}{5} \left( \frac{2}{3}x + 2 \right) + 1 \right] > 0 \right)$$

$$\text{Inequality} = \left( \frac{17}{30}x - \frac{22}{15} > 0 \right)$$

$$\text{Inequality} = \left( \frac{17}{30}x > 0 + \frac{22}{15} \right)$$

$$\text{Inequality} = \left( x > \frac{44}{17} \right)$$

$$\text{Inequality} = \left( x > \frac{44}{17} \right)$$

$$\text{Inequality} = \left( x > \frac{44}{17} \right)$$

$$\text{Inequality} = (x > 2.5882)$$

Below we graph the solution. If the endpoint of the solution set is a solid circle, then the endpoint is included in the solution set. If the endpoint is a hollow circle, then it is not in the solution set.

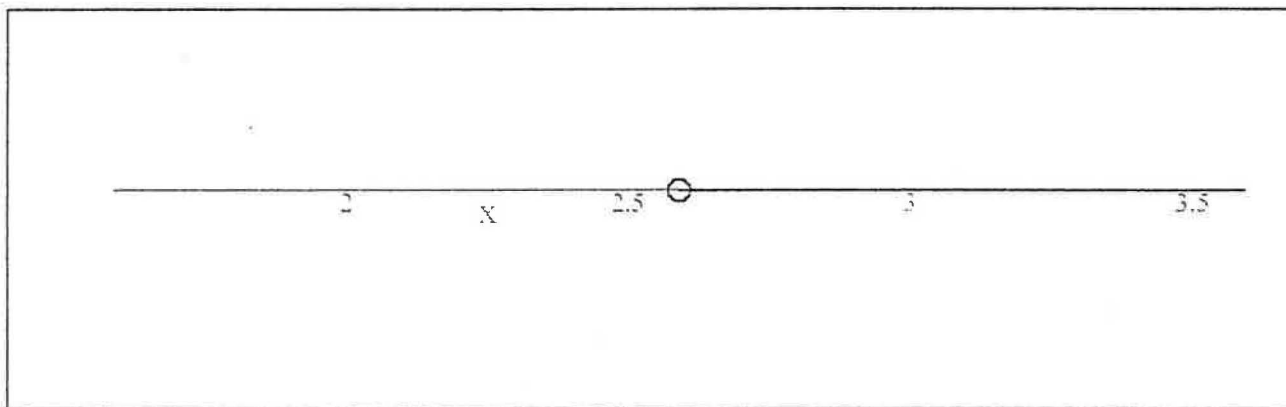

## Linear Inequalities: LHS > RHS

Please enter the left hand side (LHS) of the inequality below.

$$\text{LHS} = \frac{\left(-\frac{1}{2}x + 2\left[3 - \frac{4}{3}x\right]\right) + 1}{4}$$

This simplifies as:

$$\text{LHS} = -\frac{19}{24}x + \frac{7}{4}$$

Please enter the right hand side (RHS) of the inequality below.

$$\text{RHS} = \frac{-\frac{2}{3}(3-2x) + 5\left(1 - \frac{1}{3}x\right) + \frac{3}{4}(x+1)}{4}$$

This simplifies as:

$$\text{RHS} = \frac{27}{80}x - \frac{13}{80}$$

So, after simplification, your inequality becomes:

$$-\frac{19}{24}x + \frac{7}{4} > \frac{27}{80}x - \frac{13}{80}$$

Now we proceed to solve the inequality.

$$\left(-\frac{19}{24}x + \frac{7}{4}\right) - \left(\frac{27}{80}x - \frac{13}{80}\right) > 0$$

$$-\frac{271}{240}x + \frac{153}{80} > 0$$

$$x < \frac{459}{271}$$

$$x < 1.6937$$

Below is a graph of the solution on the number line.

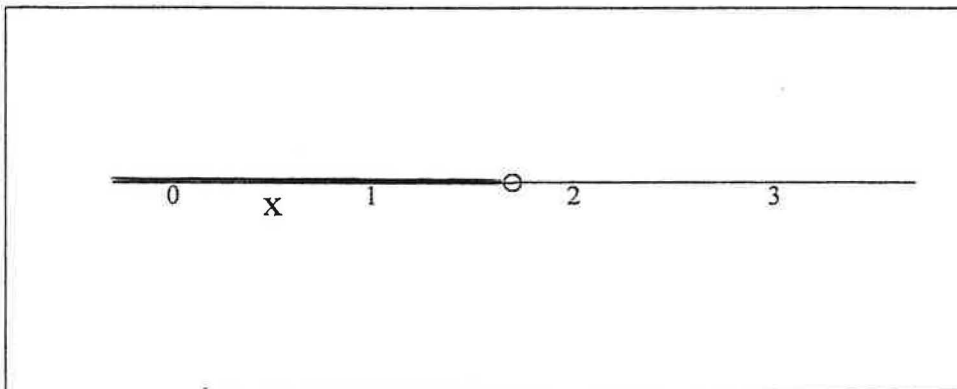

And below we have the plot of the left side of the inequality in black, and the right side is in blue. Since we are interested in when the left side is greater than the right side, the solution is where the black graph is higher than the blue graph. This happens on the region where the number line is colored red.

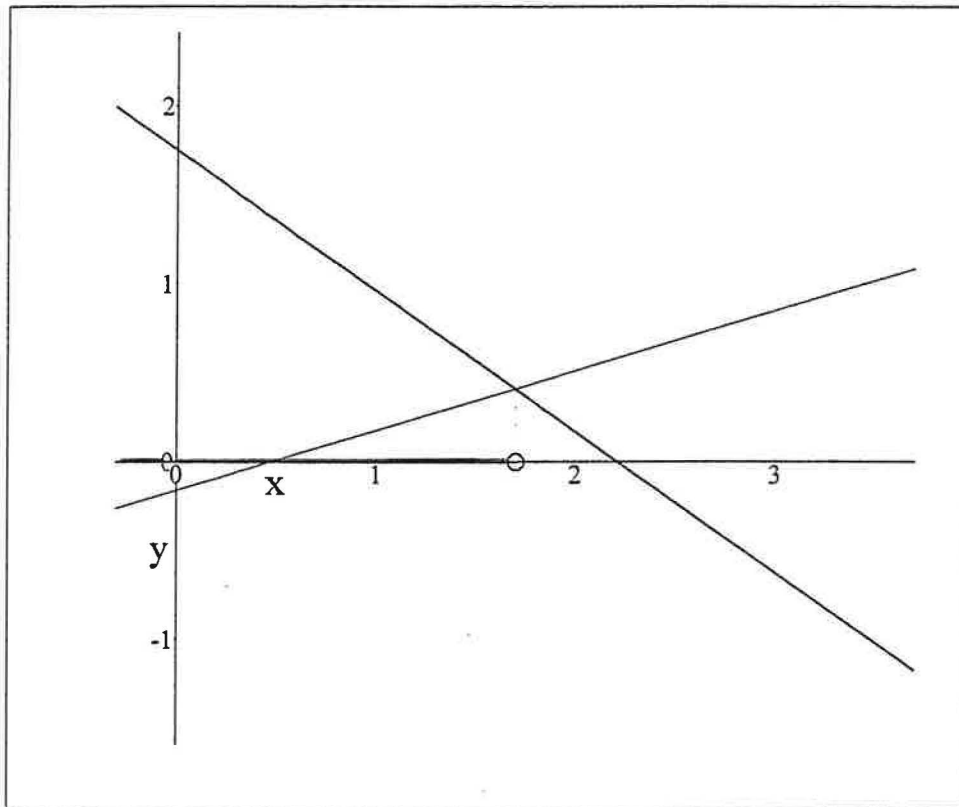

Copyright July 2000 by Scott Guth  
Mt. San Antonio College



## Linear Inequalities: LHS $\geq$ RHS

Please enter the left hand side (LHS) of the inequality below.

$$\text{LHS} = \frac{\left(-\frac{1}{2}x + 2\left[3 - \frac{4}{3}x\right]\right) + 1}{4}$$

This simplifies as:

$$\text{LHS} = -\frac{19}{24}x + \frac{7}{4}$$

Please enter the right hand side (RHS) of the inequality below.

$$\text{RHS} = \frac{-\frac{2}{3}(3 - 2x) + 5\left(1 - \frac{1}{3}x\right)}{5} + \frac{3}{4}(x + 1)$$

This simplifies as:

$$\text{RHS} = \frac{27}{80}x - \frac{13}{80}$$

So, after simplification, your inequality becomes:

$$-\frac{19}{24}x + \frac{7}{4} \geq \frac{27}{80}x - \frac{13}{80}$$

Now we proceed to solve the inequality.

$$\left(-\frac{19}{24}x + \frac{7}{4}\right) - \left(\frac{27}{80}x - \frac{13}{80}\right) \geq 0$$

$$-\frac{271}{240}x + \frac{153}{80} \geq 0$$

$$x \leq \frac{459}{271}$$

$$x \leq 1.6937$$

Below is a graph of the solution on the number line.

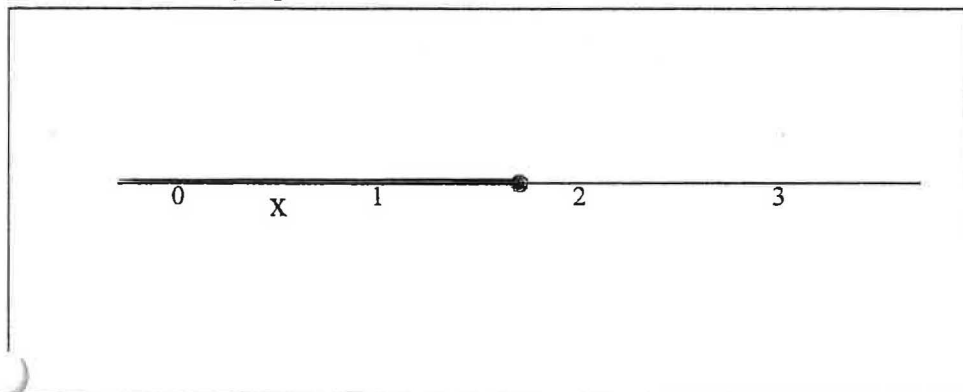

And below we have the plot of the left side of the inequality in black, and the right side is in blue. Since we are interested in when the left side is greater than or equal to the right side, the solution is where the black graph is higher than the blue graph. This happens on the region where the number line is colored red.

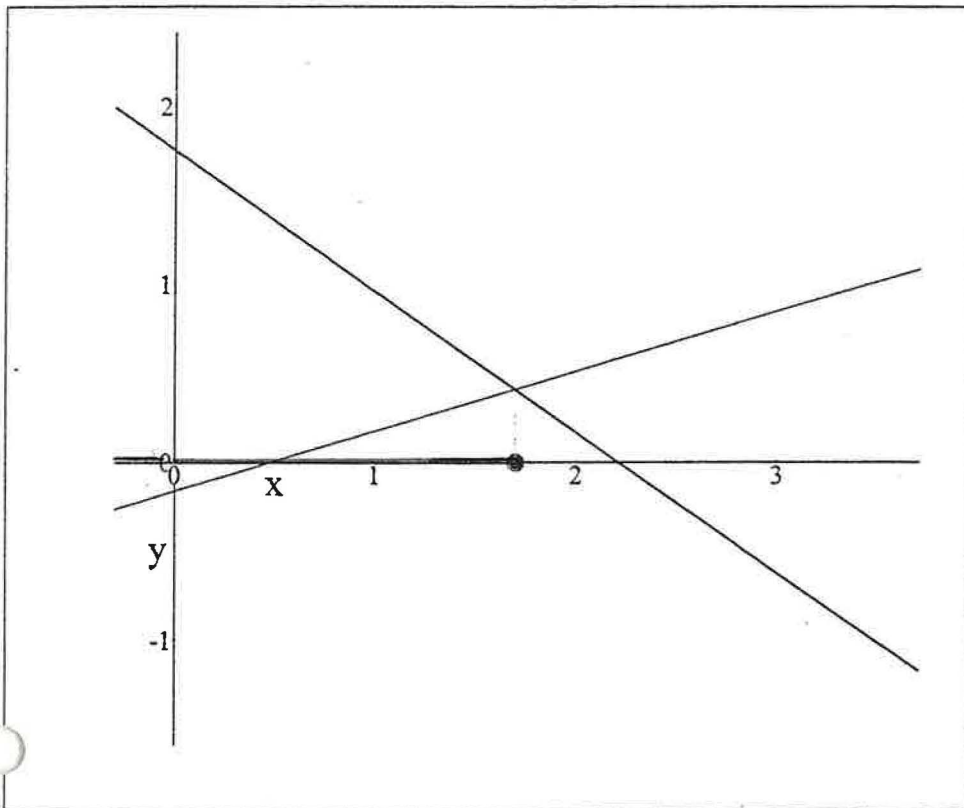

Copyright July 2000 by Scott Guth  
Mt. San Antonio College

## Linear Inequalities: LHS < RHS

Please enter the left hand side (LHS) of the inequality below.

$$\text{LHS} = \left(-\frac{1}{4}x + 2\left[3 - \frac{4}{5}x\right]\right) + 2$$

This simplifies as:

$$\text{LHS} = -\frac{37}{20}x + 8$$

Please enter the right hand side (RHS) of the inequality below.

$$\text{RHS} = \left(\frac{2}{5}[3 - 2x] + 5\right) + \frac{3}{5}$$

This simplifies as:

$$\text{RHS} = -\frac{4}{5}x + \frac{34}{5}$$

So, after simplification, your inequality becomes:

$$-\frac{37}{20}x + 8 < -\frac{4}{5}x + \frac{34}{5}$$

Now we proceed to solve the inequality.

$$\left(-\frac{37}{20}x + 8\right) - \left(-\frac{4}{5}x + \frac{34}{5}\right) < 0$$

$$-\frac{21}{20}x + \frac{6}{5} < 0$$

$$x > \frac{8}{7}$$

$$x > 1.1429$$

Below is a graph of the solution on the number line.

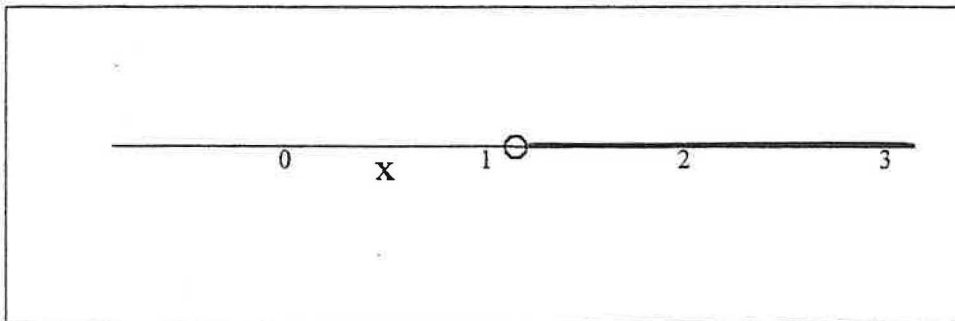

And below we have the plot of the left side of the inequality in black, and the right side is in blue. Since we are interested in when the left side is less than the right side, the solution is where the black graph is lower than the blue graph. This happens on the region where the number line is colored red.

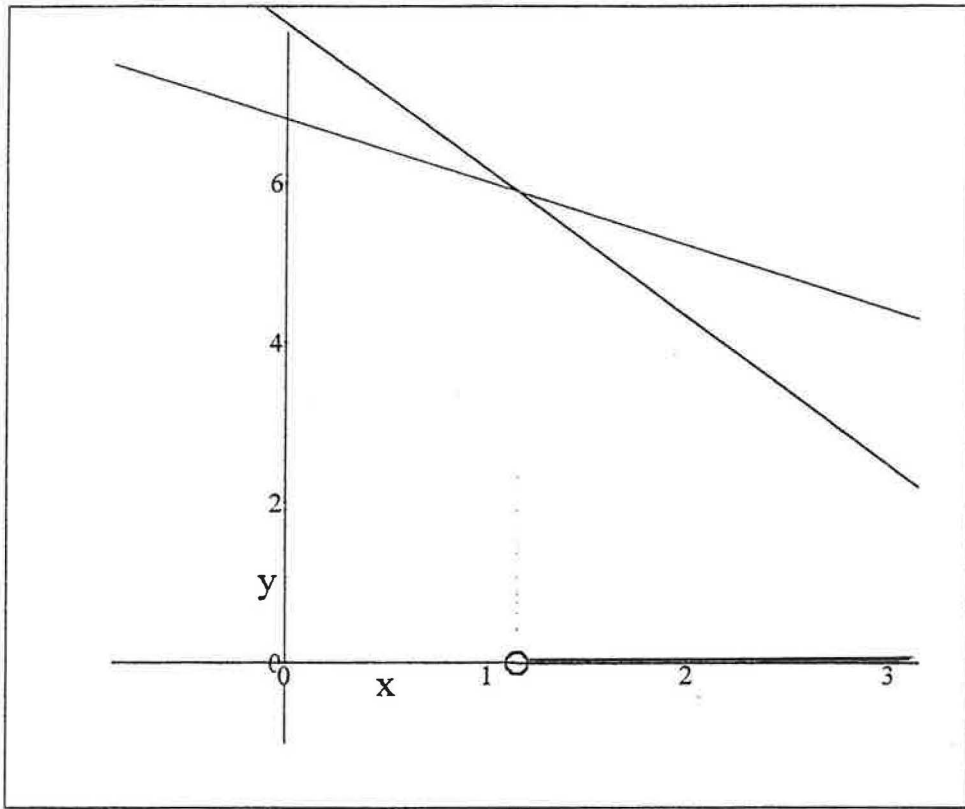

Copyright July 2000 by Scott Guth  
Mt. San Antonio College

## Linear Inequalities: LHS $\leq$ RHS

Please enter the left hand side (LHS) of the inequality below.

$$\text{LHS} = \frac{\left(-\frac{1}{2}x + 2\left[3 - \frac{4}{3}x\right]\right) + 1}{4}$$

This simplifies as:

$$\text{LHS} = -\frac{19}{24}x + \frac{7}{4}$$

Please enter the right hand side (RHS) of the inequality below.

$$\text{RHS} = \frac{-\frac{2}{3}(3 - 2x) + 5\left(1 - \frac{1}{3}x\right) + \frac{3}{4}(x + 1)}{4}$$

This simplifies as:

$$\text{RHS} = \frac{27}{80}x - \frac{13}{80}$$

So, after simplification, your inequality becomes:

$$-\frac{19}{24}x + \frac{7}{4} \leq \frac{27}{80}x - \frac{13}{80}$$

Now we proceed to solve the inequality.

$$\left(-\frac{19}{24}x + \frac{7}{4}\right) - \left(\frac{27}{80}x - \frac{13}{80}\right) \leq 0$$

$$-\frac{271}{240}x + \frac{153}{80} \leq 0$$

$$x \geq \frac{459}{271}$$

$$x \geq 1.6937$$

Below is a graph of the solution on the number line.

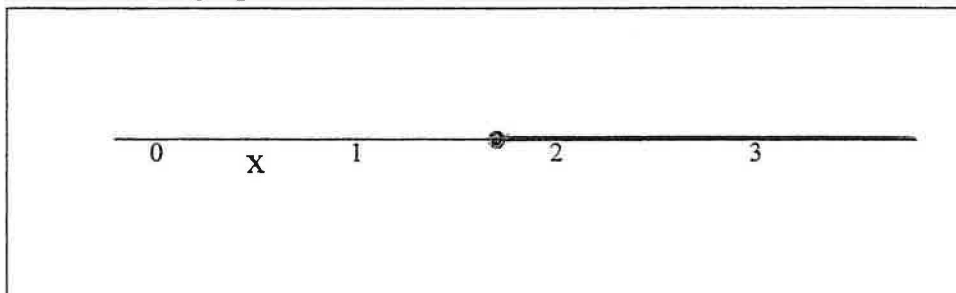

And below we have the plot of the left side of the inequality in black, and the right side is in blue. Since we are interested in when the left side is less than or equal to the right side, the solution is where the black graph is lower than the blue graph. This happens on the region where the number line is colored red.

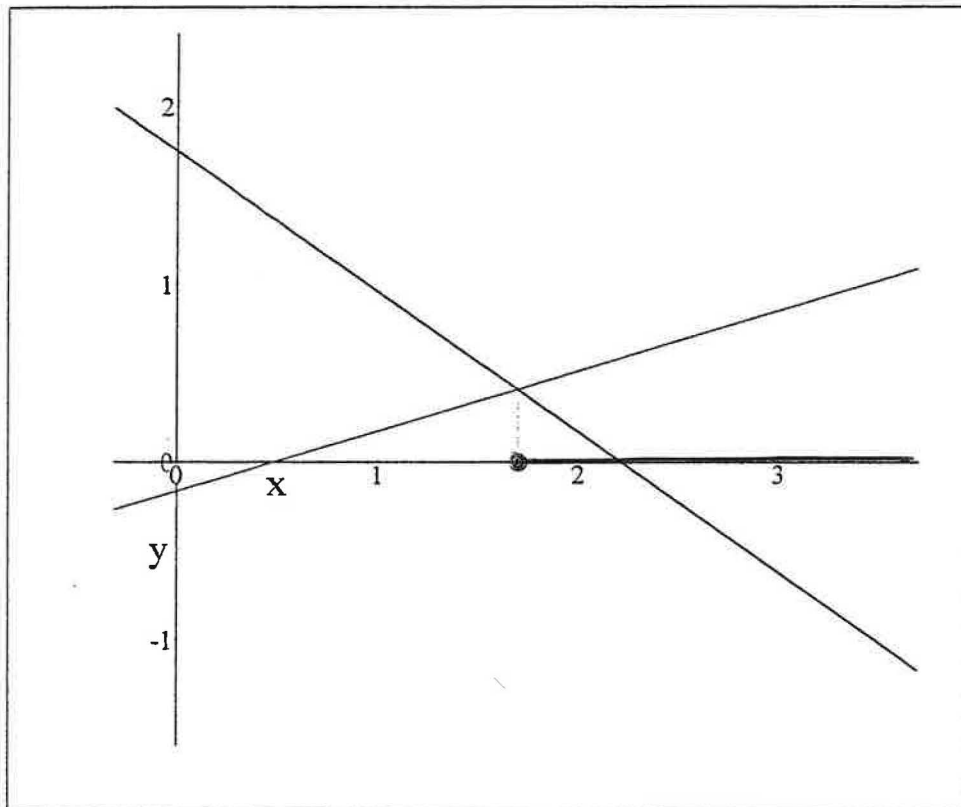

Copyright July 2000 by Scott Guth  
Mt. San Antonio College

## Plotting Quadratics

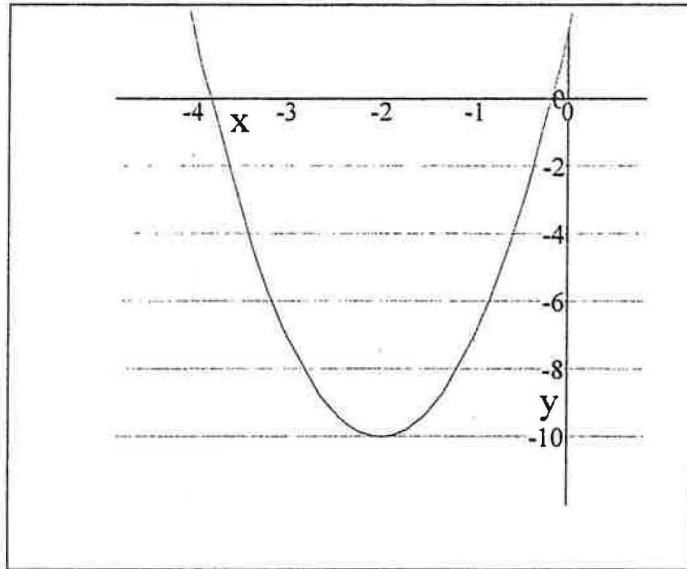

All quadratic functions can be put into standard form:  $y = a x^2 + b x + c$ . Please enter a, b, and c below.

$$a = 3 \quad b = 12 \quad c = 2$$

So your function looks like this:

$$y = 3x^2 + 12x + 2$$

Now we begin the process of completing the square. First we factor 'a' from the first two terms.

$$y = 3(x^2 + 4x) + 2$$

To complete the square, we add  $\left(\frac{1}{2} \text{ x-coefficient}\right)^2$  inside the parentheses, and balance this by subtracting this amount times 'a' outside of the parentheses.

$$y = 3(x^2 + 4x + 4) - 12 + 2$$

$$y = 3(x^2 + 4x + 4) - 10$$

Now we factor the perfect square:

$$y = 3(x + 2)^2 - 10$$

And from this form we know the coordinates of the vertex:

$$\text{vertex} = (-2, -10)$$

Below, the x-intercepts are found by setting  $y = 0$  & solving for  $x$ . If the solutions are imaginary, then there are no x-intercepts.

$$y = 0$$

$$0 = 3x^2 + 12x + 2$$

$$0 = 3\left(x + \frac{1}{3}\sqrt{30} + 2\right)\left(x - \frac{1}{3}\sqrt{30} + 2\right)$$

$$x = -\frac{1}{3}\sqrt{30} - 2$$

$$x = \frac{1}{3}\sqrt{30} - 2$$

Next, we find the y - intercept by setting  $x = 0$  & evaluating  $y$ .

$$x = 0$$

$$y = 2$$

And last, here is the graph of the function.

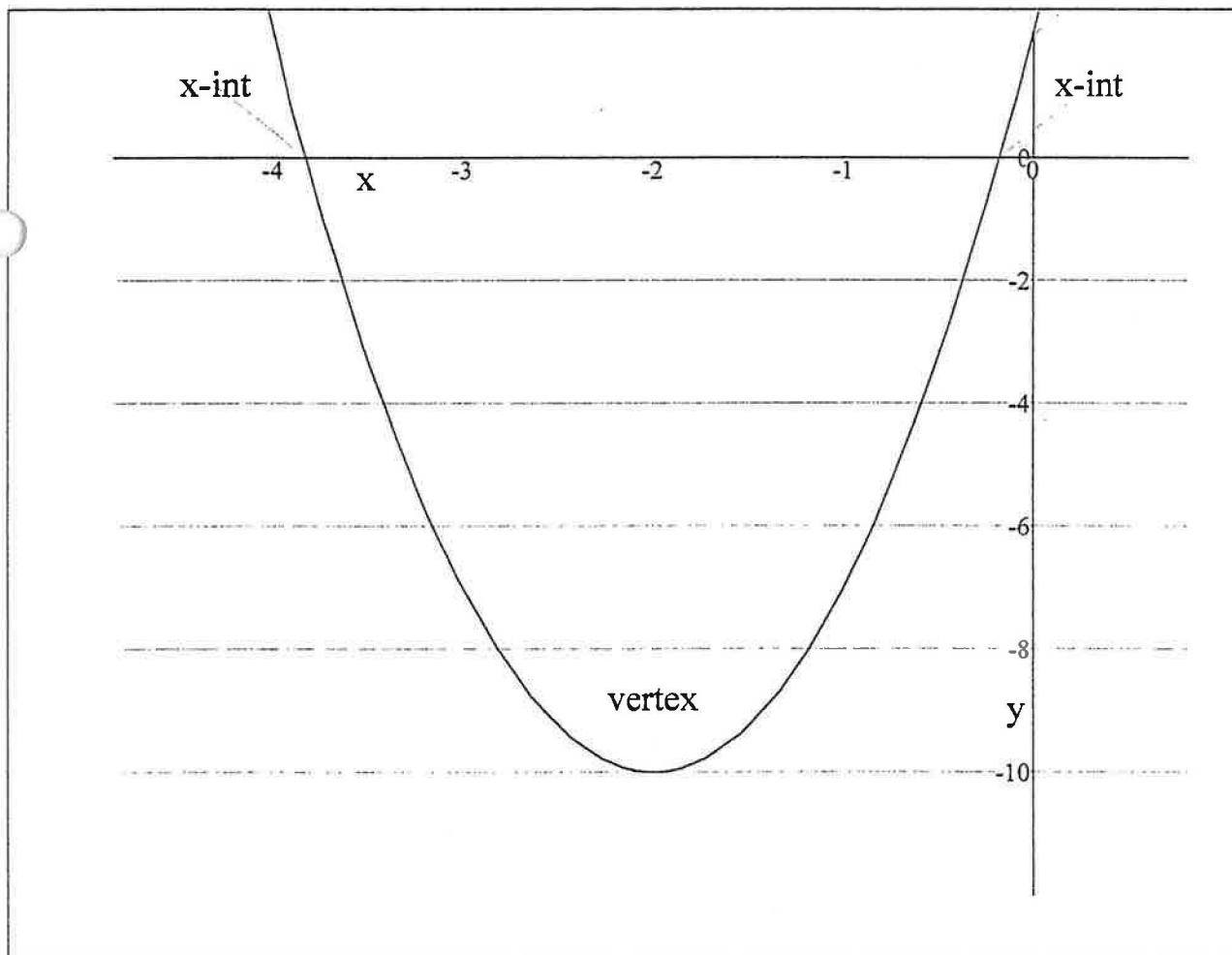



## The relationship between zeros, factors, and intercepts.

### Finding the zeros of a quadratic polynomial

Enter a function  $y_1$  below:

$$y_1 = 5x^2 + 7x - 10$$

To find the zeros, we look for  $x$  values which make  $y_1$  equal to zero.

So first we set  $y_1 = 0$ ...

$$y_1 = 0$$

Substituting this into the function you entered gives us this:

$$0 = 5x^2 + 7x - 10$$

To solve this equation, we factor...

$$0 = 5\left(x + \frac{1}{50}\sqrt{6225} + \frac{7}{10}\right)\left(x - \frac{1}{50}\sqrt{6225} + \frac{7}{10}\right)$$

And setting each factor equal to zero we get...

$$x = -\frac{1}{50}\sqrt{6225} - \frac{7}{10} \quad \text{And this approximates as:} \quad x = -2.278$$

$$x = \frac{1}{50}\sqrt{6225} - \frac{7}{10} \quad \text{And this approximates as:} \quad x = 0.87797$$

Now for the plot of the function. Recall that to find the  $x$ -intercepts of a function, we set the function equal to zero and solve for  $x$ . This is precisely what we did to find the zeros of the function. So the zeros are the  $x$ -intercepts. They are labelled as  $x_1$  and  $x_2$  in the graph below.

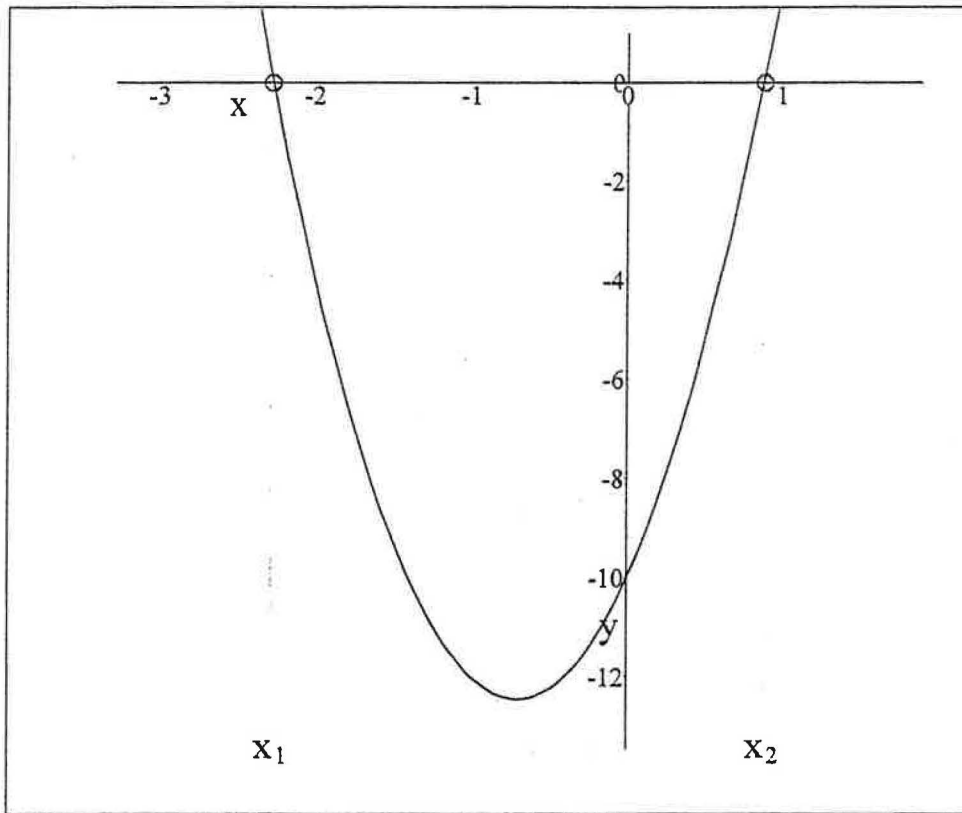

### Finding the roots of a cubic polynomial...

Enter a function  $y_2$  below.

$$y_2 = x^3 - 5x^2 + 6x$$

To find the zeros, we look for  $x$  values which make  $y_1$  equal to zero.

So first we set  $y_1 = 0$ ...

$$y_2 = 0$$

Substituting this into the function you entered gives us this:

$$0 = x^3 - 5x^2 + 6x$$

Next, we factor. With a third degree polynomial, this can get very messy!

$$0 = (x - 3)(x - 2)x$$

Finally, we set each factor equal to zero to find the zeros of the function.

The first zero is:

$$x = 3$$

And the first zero approximates to this:  $x = 3$

The second zero is:

$$x = 2$$

And the second zero approximates to this:  $x = 2$

The third zero is:

$$x = 0$$

And the third zero approximates to this:  $x = 0$

Now for the plot of the function. Recall that to find the x-intercepts of a function, we set the function equal to zero and solve for x. This is precisely what we did to find the zeros of the function. So the zeros are the x-intercepts. They are labelled as  $x_1$ ,  $x_2$ , and  $x_3$  in the graph below.

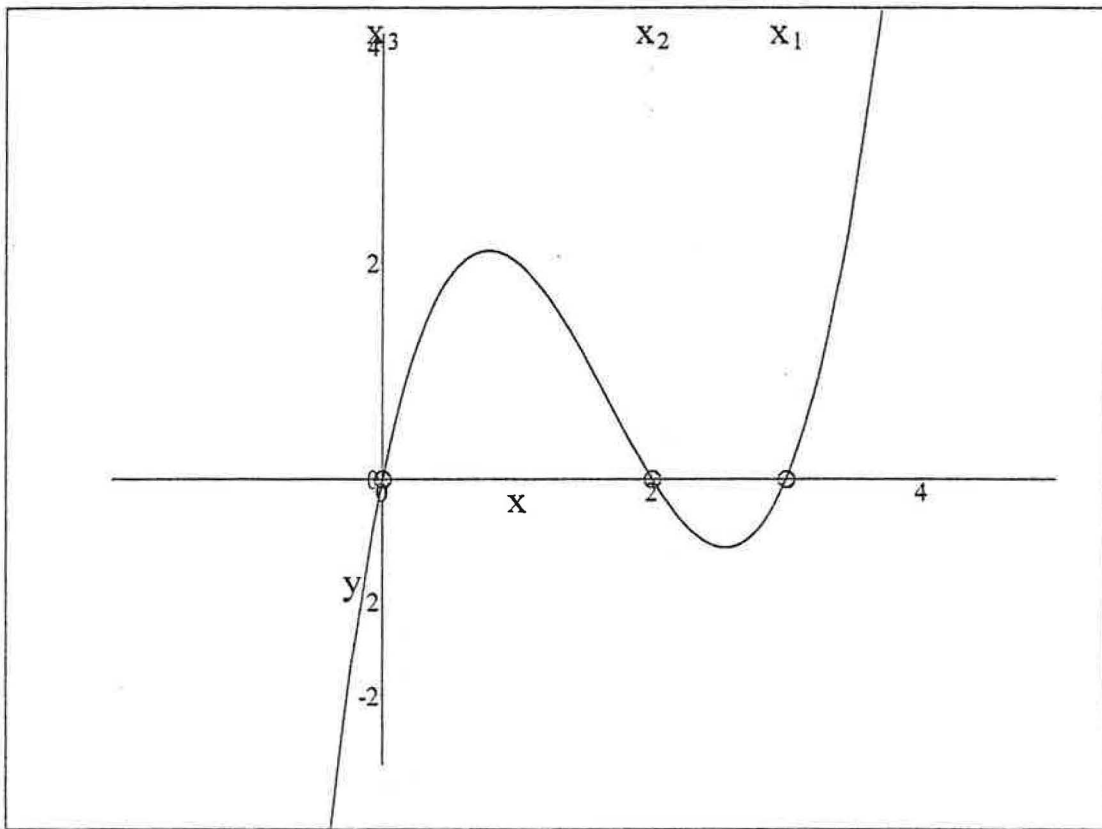

Copyright July 2000 by Scott Guth  
Mt. San Antonio College

## Polynomial Inequalities: LHS > RHS.

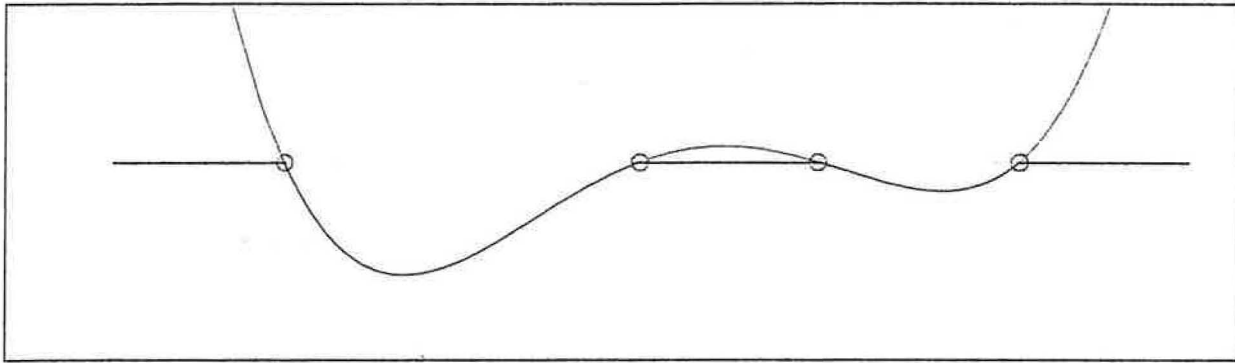

Please enter the left and right hand sides (LHS and RHS) of your inequality below.

$$\text{LHS} = x^4 + 2x - 1$$

$$\text{RHS} = 5x^2 - 2$$

Click here \* when finished.

So the inequality that we will solve is:

$$x^4 + 2x - 1 > 5x^2 - 2$$

Let "sum" denote the difference between the left- and right-hand sides.

$$\text{sum} = \text{LHS} - \text{RHS}$$

So when we subtract we get...

$$\text{sum} = x^4 - 5x^2 + 2x + 1$$

So our inequality looks like

$$x^4 - 5x^2 + 2x + 1 > 0$$

After factoring, our inequality looks like this:

$$(x + 0.29137)(x - 0.75102)(x - 1.9202)(x + 2.3799) > 0$$

Our next step is to set each factor equal to zero & solve. Each solution is a "Boundary Point."

Edit the "BoundaryPoints" list below to include all of the boundary points for your problem. Type a comma after each point entered.

THE BOUNDARY POINTS MUST BE ORDERED FROM LOW TO HIGH! ;-)

BoundaryPoints = (-2.3799, -0.29137, 0.75102, 1.9202)

Click here \* when finished.

The boundary points entered divide the number line into regions. Using the boundary points that you entered, a "Test Point" from each region has been generated and the inequality has been tested. When  $\text{sum} > 0$  for a given test point, the inequality will be true over the test point's entire region. When  $\text{sum} \leq 0$  for a given test point, the inequality will be false over that test point's entire region.

The regions, test points, and conclusions are summarized in the table below.

$$M = \begin{pmatrix} \text{Region} & \text{LowerLimit} & \text{UpperLimit} & \text{TestPoint} & \text{sum} & \text{TorF} \\ \text{I} & -\infty & -2.3799 & -3.3799 & 67.62 & \text{T} \\ \text{II} & -2.3799 & -0.29137 & -1.3356 & -7.4084 & \text{F} \\ \text{III} & -0.29137 & 0.75102 & 0.22983 & 1.1983 & \text{T} \\ \text{IV} & 0.75102 & 1.9202 & 1.3356 & -2.0659 & \text{F} \\ \text{V} & 1.9202 & \infty & 2.9202 & 36.923 & \text{T} \end{pmatrix}$$

And the solution of the inequality is plotted below. For strict inequalities like this one (without the "or-equal"), boundary points are never included in the solution set.

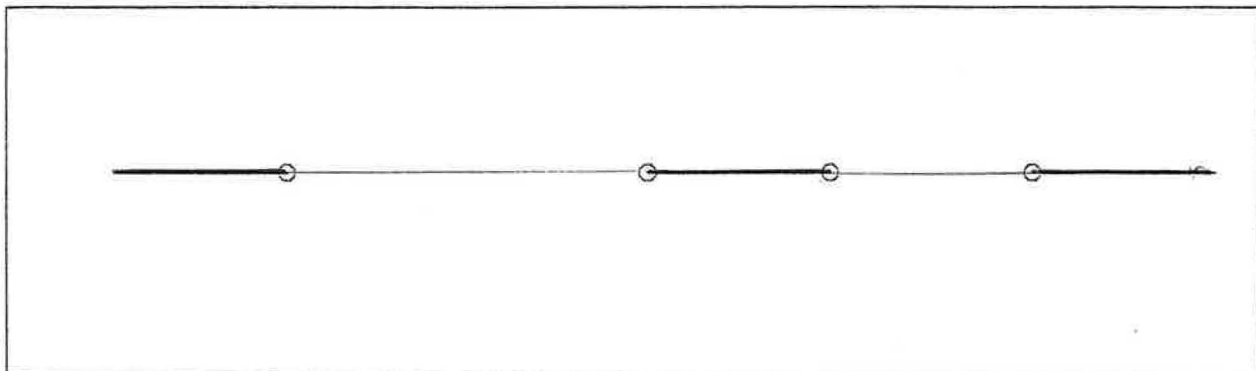

Below we graph  $y = \text{sum}$ . Where  $\text{sum} > 0$  the inequality is true, and the graph is colored red. Where  $\text{sum} \leq 0$  the inequality is false, and the graph is colored blue. So the inequality is true whenever the graph is above the x-axis.

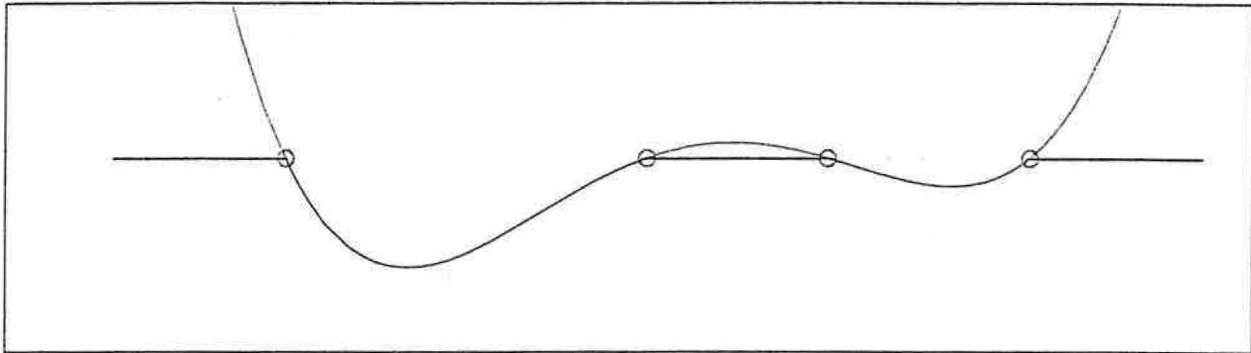

Copyright July 2000 by Scott Guth  
Mt. San Antonio College

## Polynomial Inequalities: $LHS \geq RHS$ .

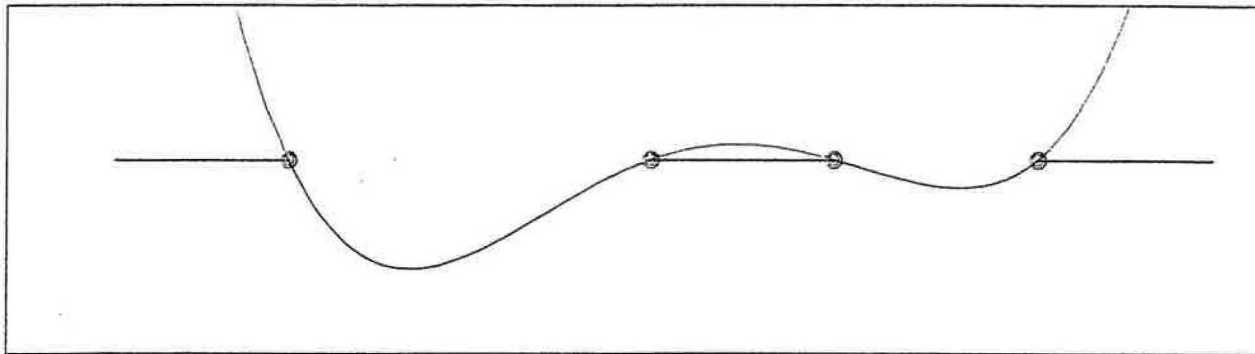

Please enter the left and right hand sides (LHS and RHS) of your inequality below.

$$LHS = x^4 + 2x - 1$$

$$RHS = 5x^2 - 2$$

Click here \* when finished.

So the inequality that we will solve is:

$$x^4 + 2x - 1 \geq 5x^2 - 2$$

Let "sum" denote the difference between the left- and right-hand sides.

$$\text{sum} = LHS - RHS$$

So when we subtract we get...

$$\text{sum} = x^4 - 5x^2 + 2x + 1$$

So our inequality looks like

$$x^4 - 5x^2 + 2x + 1 \geq 0$$

After factoring, our inequality looks like this:

$$(x + 0.29137)(x - 0.75102)(x - 1.9202)(x + 2.3799) \geq 0$$

Our next step is to set each factor equal to zero & solve. Each solution is a "Boundary Point."

Edit the "BoundaryPoints" list below to include all of the boundary points for your problem. Type a comma after each point entered.

THE BOUNDARY POINTS MUST BE ORDERED FROM LOW TO HIGH! ;-)

BoundaryPoints = (-2.3799, -0.29137, 0.75102, 1.9202)

Click here \* when finished.

The boundary points entered divide the number line into regions. Using the boundary points that you entered, a "Test Point" from each region has been generated and the inequality has been tested. When  $\text{sum} \geq 0$  for a given test point, the inequality will be true over the test point's entire region. When  $\text{sum} < 0$  for a given test point, the inequality will be false over that test point's entire region.

The regions, test points, and conclusions are summarized in the table below.

$$M = \begin{pmatrix} \text{Region} & \text{LowerLimit} & \text{UpperLimit} & \text{TestPoint} & \text{sum} & \text{TorF} \\ \text{I} & -\infty & -2.3799 & -3.3799 & 67.62 & \text{T} \\ \text{II} & -2.3799 & -0.29137 & -1.3356 & -7.4084 & \text{F} \\ \text{III} & -0.29137 & 0.75102 & 0.22983 & 1.1983 & \text{T} \\ \text{IV} & 0.75102 & 1.9202 & 1.3356 & -2.0659 & \text{F} \\ \text{V} & 1.9202 & \infty & 2.9202 & 36.923 & \text{T} \end{pmatrix}$$

The final step is to test the inequality at the Boundary Points. In this case, the inequality is true whenever  $\text{sum} \geq 0$ , and since  $\text{sum} = 0$  at each boundary point, we include all of them in the solution set.

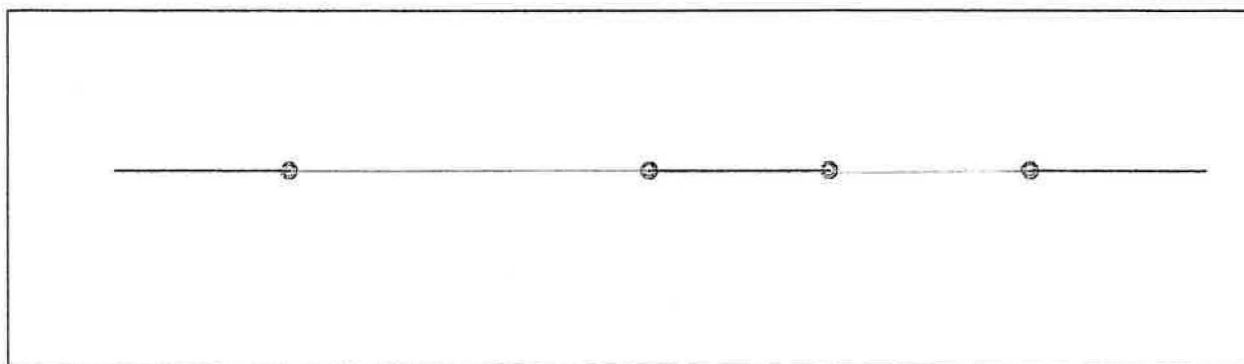



Below we graph  $y = \text{sum}$ . Where  $\text{sum} \geq 0$  the inequality is true, and the graph is colored red. Where  $\text{sum} < 0$  the inequality is false, and the graph is colored blue. So the inequality is true whenever the graph is above or on the x-axis.

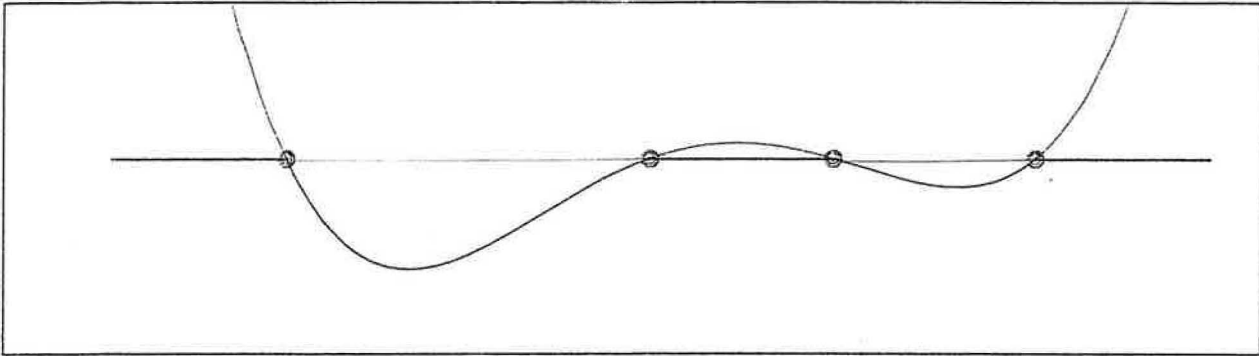

Copyright July 2000 by Scott Guth  
Mt. San Antonio College

## Polynomial Inequalities: LHS < RHS.

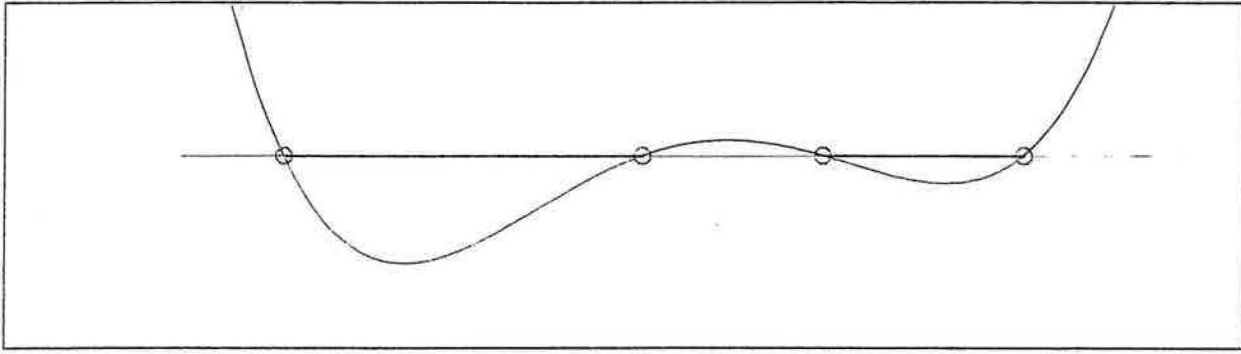

Please enter the left and right hand sides (LHS and RHS) of your inequality below.

$$\text{LHS} = x^4 + 2x - 1$$

$$\text{RHS} = 5x^2 - 2$$

Click here \* when finished.

So the inequality that we will solve is:

$$\textcircled{O} \quad x^4 + 2x - 1 < 5x^2 - 2$$

Let "sum" denote the difference between the left- and right-hand sides.

$$\text{sum} = \text{LHS} - \text{RHS}$$

So when we subtract we get...

$$\text{sum} = x^4 - 5x^2 + 2x + 1$$

So our inequality looks like

$$x^4 - 5x^2 + 2x + 1 < 0$$

After factoring, our inequality looks like this:

$$\textcircled{O} \quad (x + 0.29137)(x - 0.75102)(x - 1.9202)(x + 2.3799) < 0$$

Our next step is to set each factor equal to zero & solve. Each solution is a "Boundary Point."

Edit the "BoundaryPoints" list below to include all of the boundary points for your problem. Type a comma after each point entered.

THE BOUNDARY POINTS MUST BE ORDERED FROM LOW TO HIGH! ;-)

BoundaryPoints = (-2.3799, -0.29137, 0.75102, 1.9202)

Click here \* when finished.

The boundary points entered divide the number line into regions. Using the boundary points that you entered, a "Test Point" from each region has been generated and the inequality has been tested. When  $\text{sum} < 0$  for a given test point, the inequality will be true over the test point's entire region. When  $\text{sum} \geq 0$  for a given test point, the inequality will be false over that test point's entire region.

The regions, test points, and conclusions are summarized in the table below.

$$M = \begin{pmatrix} \text{Region} & \text{LowerLimit} & \text{UpperLimit} & \text{TestPoint} & \text{sum} & \text{TorF} \\ \text{I} & -\infty & -2.3799 & -3.3799 & 67.62 & \text{T} \\ \text{II} & -2.3799 & -0.29137 & -1.3356 & -7.4084 & \text{F} \\ \text{III} & -0.29137 & 0.75102 & 0.22983 & 1.1983 & \text{T} \\ \text{IV} & 0.75102 & 1.9202 & 1.3356 & -2.0659 & \text{F} \\ \text{V} & 1.9202 & \infty & 2.9202 & 36.923 & \text{T} \end{pmatrix}$$

And the solution of the inequality is plotted below. For strict inequalities like this one (without the "or-equal"), boundary points are never included in the solution set.

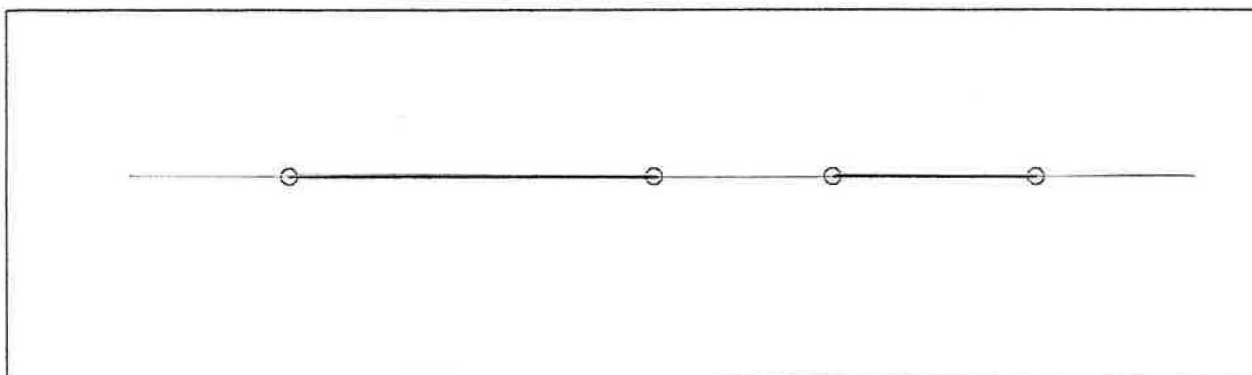

Below we graph  $y = \text{sum}$ . Where  $\text{sum} < 0$  the inequality is true, and the graph is colored red. Where  $\text{sum} \geq 0$  the inequality is false, and the graph is colored blue. So the inequality is true whenever the graph is below the x-axis.

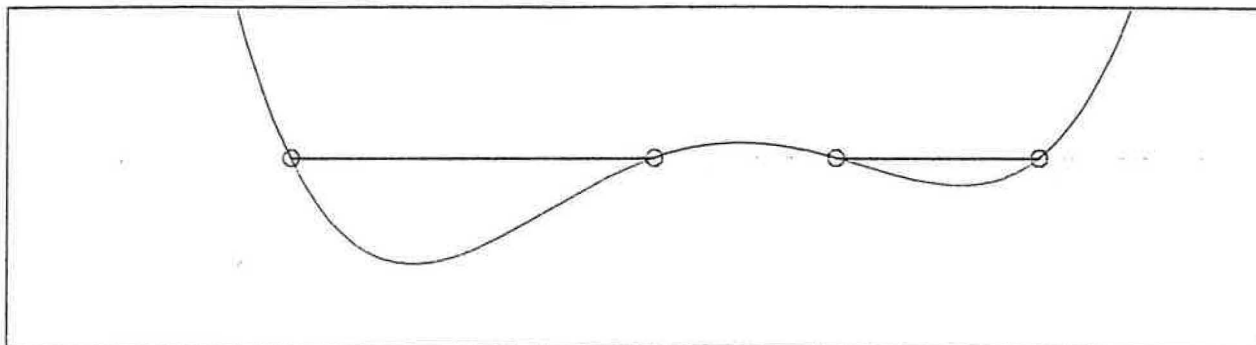

Copyright July 2000 by Scott Guth  
Mt. San Antonio College

## Polynomial Inequalities: $LHS \leq RHS$ .

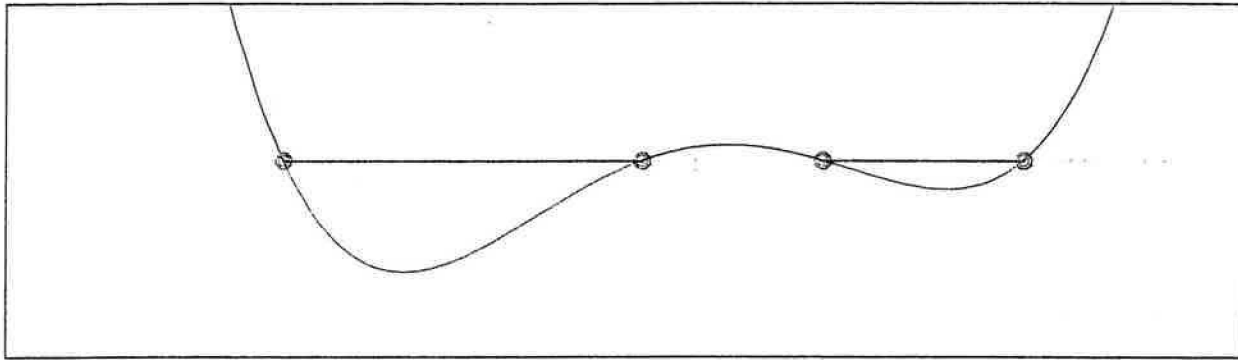

Please enter the left and right hand sides (LHS and RHS) of your inequality below.

$$\text{LHS} = x^4 + 2x - 1$$

$$\text{RHS} = 5x^2 - 2$$

Click here \* when finished.

So the inequality that we will solve is:

$$x^4 + 2x - 1 \leq 5x^2 - 2$$

Let "sum" denote the difference between the left- and right-hand sides.

$$\text{sum} = \text{LHS} - \text{RHS}$$

So when we subtract we get...

$$\text{sum} = x^4 - 5x^2 + 2x + 1$$

So our inequality looks like

$$x^4 - 5x^2 + 2x + 1 \leq 0$$

After factoring, our inequality looks like this:

$$(x + 0.29137)(x - 0.75102)(x - 1.9202)(x + 2.3799) \leq 0$$

Our next step is to set each factor equal to zero & solve. Each solution is a "Boundary Point."

Edit the "BoundaryPoints" list below to include all of the boundary points for your problem. Type a comma after each point entered.

THE BOUNDARY POINTS MUST BE ORDERED FROM LOW TO HIGH! ;-)

BoundaryPoints = (-2.3799, -0.29137, 0.75102, 1.9202)

Click here \* when finished.

The boundary points entered divide the number line into regions. Using the boundary points that you entered, a "Test Point" from each region has been generated and the inequality has been tested. When  $\text{sum} \leq 0$  for a given test point, the inequality will be true over the test point's entire region. When  $\text{sum} > 0$  for a given test point, the inequality will be false over that test point's entire region.

The regions, test points, and conclusions are summarized in the table below.

$$M = \begin{pmatrix} \text{Region} & \text{LowerLimit} & \text{UpperLimit} & \text{TestPoint} & \text{sum} & \text{TorF} \\ \text{I} & -\infty & -2.3799 & -3.3799 & 67.62 & \text{F} \\ \text{II} & -2.3799 & -0.29137 & -1.3356 & -7.4084 & \text{T} \\ \text{III} & -0.29137 & 0.75102 & 0.22983 & 1.1983 & \text{F} \\ \text{IV} & 0.75102 & 1.9202 & 1.3356 & -2.0659 & \text{T} \\ \text{V} & 1.9202 & \infty & 2.9202 & 36.923 & \text{F} \end{pmatrix}$$

The final step is to test the inequality at the Boundary Points. In this case, the inequality is true whenever  $\text{sum} \leq 0$ , and since  $\text{sum} = 0$  at each boundary point, we include all of them in the solution set.

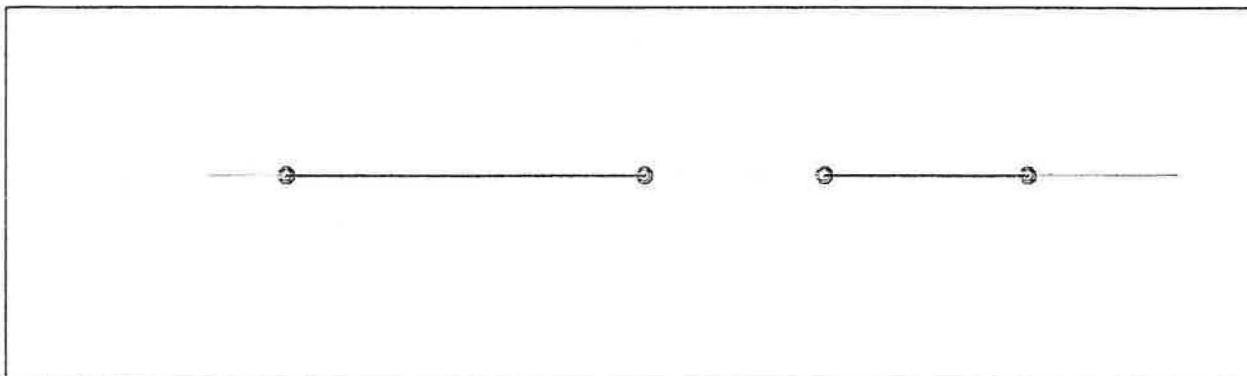

Below we graph  $y = \text{sum}$ . Where  $\text{sum} \leq 0$  the inequality is true, and the graph is colored red. Where  $\text{sum} > 0$  the inequality is false, and the graph is colored blue. So the inequality is true whenever the graph is below or on the x-axis.

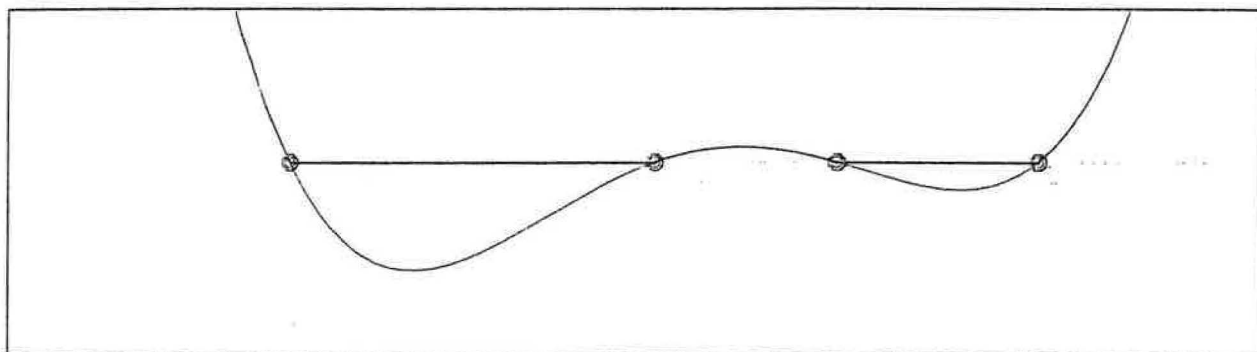

Copyright July 2000 by Scott Guth  
Mt. San Antonio College

## Rational Inequalities: LHS > RHS

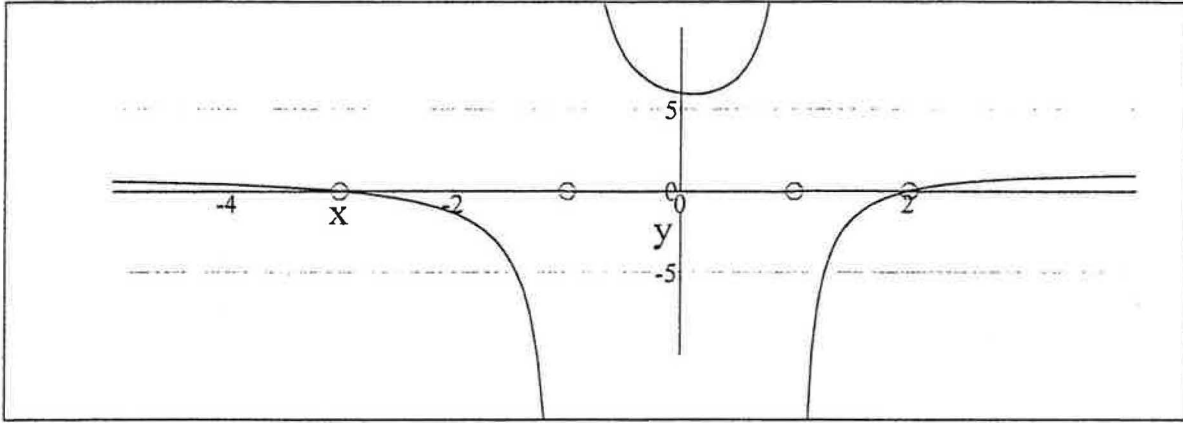

Please enter the left- and right-hand sides of your inequality below.

$$\text{LHS} = \frac{2x+5}{x+1}$$

$$\text{RHS} = \frac{x+1}{x-1}$$

Click here \* when finished.

So your inequality looks like this:

$$\frac{2x+5}{x+1} > \frac{x+1}{x-1}$$

We first move the terms on the Right-Hand-Side (RHS) to the left. This results in the inequality below.

$$-\frac{x+1}{x-1} + \frac{2x+5}{x+1} > 0$$

Next, must sum the terms on the left. Let "sum" denote this expression.

$$\text{sum} = -\frac{x+1}{x-1} + \frac{2x+5}{x+1}$$

In order to sum these terms, we need to know the Lowest Common Denominator for the sum. The list LD below is the List of Denominators after factoring.

$$\text{LD} = (x-1, x+1, 1, 1)$$



Using the List of Denominators above, please type the Lowest Common Denominator (LCD) below. (Recall that the LCD is the product of each appearing factor, where each factor is raised to the highest power to which a that factor appears, respectively).

$$\text{LCD} = (x - 1)(x + 1)$$

Click here \* when finished.

Using the LCD given by you, we add the terms on the LHS to create the "sum" below.

$$\begin{aligned} \text{sum} &= \frac{-(-x-1)^2 + (x-1)(2x+5)}{(x+1)(x-1)} \\ \text{sum} &= \frac{x^2 + x - 6}{(x+1)(x-1)} \end{aligned}$$

Next, we factor the numerator, if possible.

$$\text{sum} = \frac{(x+3)(x-2)}{(x+1)(x-1)}$$

Our inequality now becomes:

$$\frac{(x+3)(x-2)}{(x+1)(x-1)} > 0$$

That is, we are trying to determine what values of x cause our sum to be greater than zero.

Now we make a list of boundary points. These are the zeros of each factor in the numerator and the denominator. Please enter these values below. To create a list, just type a comma after each value to add a new value to the list. (This worksheet only allows 4 boundary points!) **THE BOUNDARY POINTS MUST BE SORTED FROM LOW TO HIGH.**

$$\text{boundarypoints} = (-3, -1, 1, 2)$$

Click here \* when finished.

Next we create a table. The boundary points divide the number line into regions. From each of these regions we pick a test point (x). Next we evaluate the "sum" which was the left - hand - side minus the right - hand - side. If the sum is less than zero, then the inequality is true.

For each region, the open interval being tested is (LowerLimit, UpperLimit). The Lower and Upper Limits for each interval are listed in separate columns of the table.

$$M = \begin{pmatrix} \text{Region} & \text{LowerLimit} & \text{UpperLimit} & \text{TestPoint} & \text{sum} & \text{TorF} \\ \text{I} & -\infty & -3 & -4 & \frac{2}{5} & \text{T} \\ \text{II} & -3 & -1 & -2 & -\frac{4}{3} & \text{F} \\ \text{III} & -1 & 1 & 0 & 6 & \text{T} \\ \text{IV} & 1 & 2 & \frac{3}{2} & -\frac{9}{5} & \text{F} \\ \text{V} & 2 & \infty & 3 & \frac{3}{4} & \text{T} \end{pmatrix}$$

The final step is to test the inequality at the Boundary Points.

None of the boundary points are filled below, denoting that they are not part of the solution set. For strict less-than or greater-than problems (without the "or - equal") boundary points are never included. This is because the boundary points make the expression equal to zero (there's the "or - equal" that we don't want) or undefined, neither of which are what we are looking for in this case.

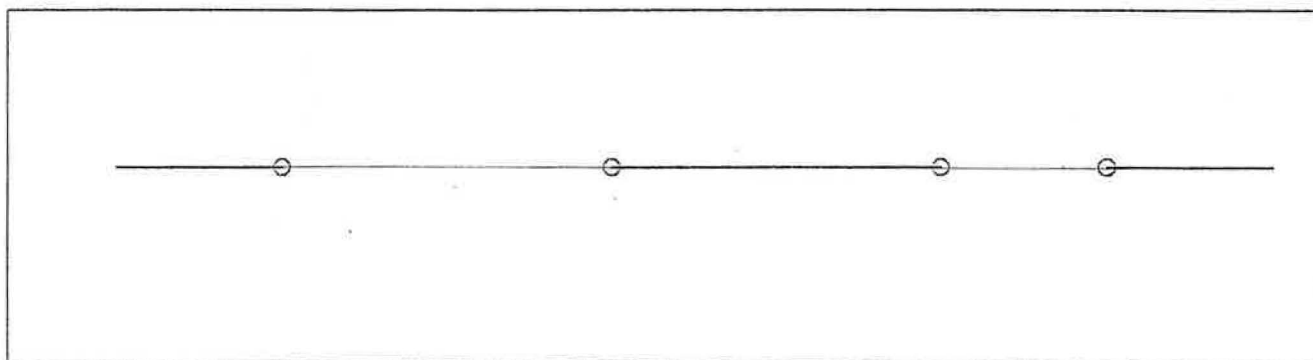

## Rational Inequalities: LHS ≥ RHS

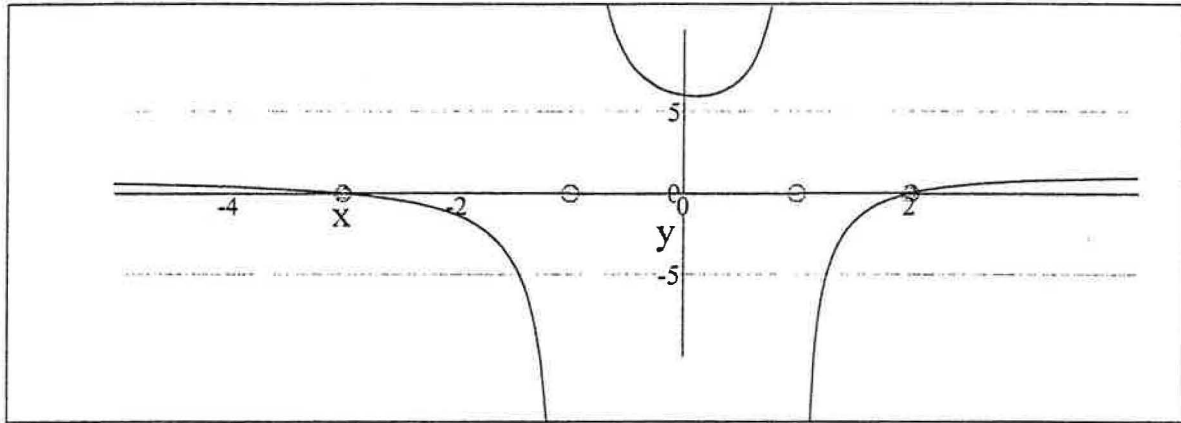

Please enter the left- and right-hand sides of your inequality below.

$$\text{LHS} = \frac{2x + 5}{x + 1}$$

$$\text{RHS} = \frac{x + 1}{x - 1}$$

Click here \* when finished.

So your inequality looks like this:

$$\frac{2x + 5}{x + 1} \geq \frac{x + 1}{x - 1}$$

We first move the terms on the Right - Hand - Side (RHS) to the left. This results in the inequality below.

$$-\frac{x + 1}{x - 1} + \frac{2x + 5}{x + 1} \geq 0$$

Next, must sum the terms on the left. Let "sum" denote this expression.

$$\text{sum} = -\frac{x + 1}{x - 1} + \frac{2x + 5}{x + 1}$$

In order to sum these terms, we need to know the Lowest Common Denominator for the sum. The list LD below is the List of Denominators after factoring.

$$\text{LD} = (x - 1, x + 1, 1, 1)$$

Using the List of Denominators above, please type the Lowest Common Denominator (LCD) below. (Recall that the LCD is the product of each appearing factor, where each factor is raised to the highest power to which a that factor appears, respectively).

$$\text{LCD} = (x + 1)(x - 1)$$

Click here \* when finished.

Using the LCD given by you, we add the terms on the LHS to create the "sum" below.

$$\begin{aligned} \text{sum} &= \frac{-(-x - 1)^2 + (x - 1)(2x + 5)}{(x + 1)(x - 1)} \\ \text{sum} &= \frac{x^2 + x - 6}{(x + 1)(x - 1)} \end{aligned}$$

Next, we factor the numerator, if possible.

$$\text{sum} = \frac{(x + 3)(x - 2)}{(x + 1)(x - 1)}$$

Our inequality now becomes:

$$\frac{(x + 3)(x - 2)}{(x + 1)(x - 1)} \geq 0$$

That is, we are trying to determine what values of x cause our sum to be less than zero.

Now we make a list of boundary points. These are the zeros of each factor in the numerator and the denominator. Please enter these values below. To create a list, just type a comma after each value to add a new value to the list. (This worksheet only allows 4 boundary points!) THE BOUNDARY POINTS MUST BE SORTED FROM LOW TO HIGH.

$$\text{boundarypoints} = (-3, -1, 1, 2)$$

Click here \* when finished.

Next we create a table. The boundary points divide the number line into regions. From each of these regions we pick a test point (x). Next we evaluate the "sum" which was the left - hand - side minus the right - hand - side. If the sum is less than zero, then the inequality is true.

For each region, the open interval being tested is (LowerLimit, UpperLimit). The Lower and Upper Limits for each interval are listed in separate columns of the table.

$$M = \begin{pmatrix} \text{Region} & \text{LowerLimit} & \text{UpperLimit} & \text{TestPoint} & \text{sum} & \text{TorF} \\ \text{I} & -\infty & -3 & -4 & \frac{2}{5} & \text{T} \\ \text{II} & -3 & -1 & -2 & -\frac{4}{3} & \text{F} \\ \text{III} & -1 & 1 & 0 & 6 & \text{T} \\ \text{IV} & 1 & 2 & \frac{3}{2} & -\frac{9}{5} & \text{F} \\ \text{V} & 2 & \infty & 3 & \frac{3}{4} & \text{T} \end{pmatrix}$$

The final step is to test the inequality at the Boundary Points. In this case, the inequality is true whenever  $\text{sum} \geq 0$ , and this will happen for boundary points that make the numerator of "sum" equal to zero.

The boundary points which are filled in the graph below are part of the solution set.

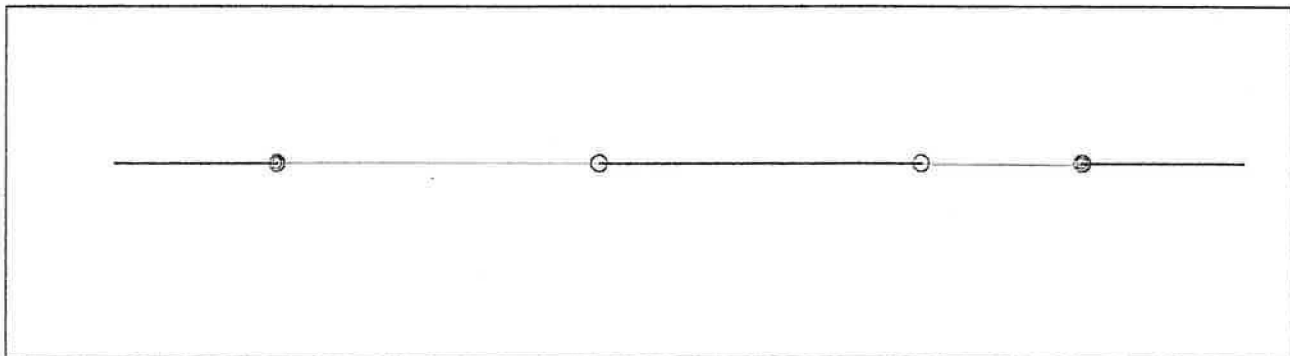

## Rational Inequalities: LHS &lt; RHS

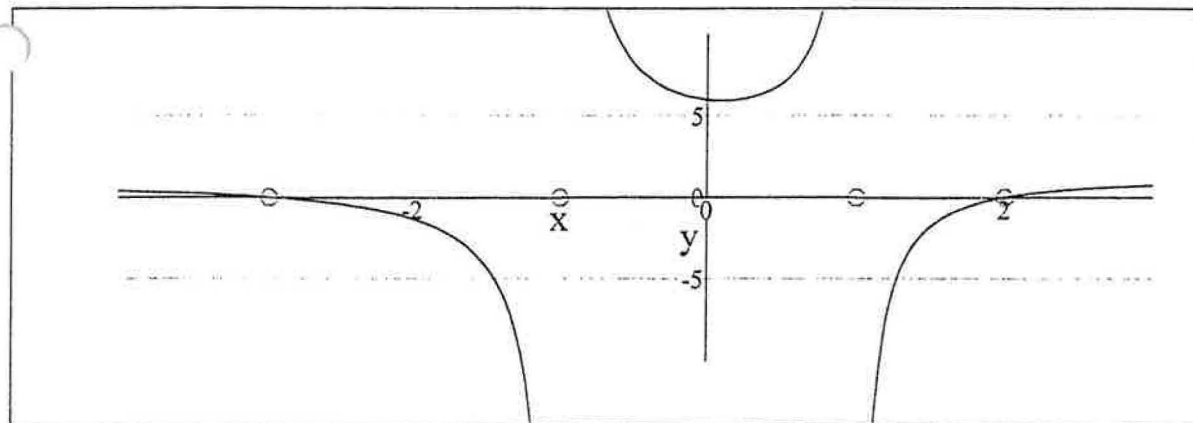

Please enter the left- and right-hand sides of your inequality below.

$$\text{LHS} = \frac{2x + 5}{x + 1}$$

$$\text{RHS} = \frac{x + 1}{x - 1}$$

Click here \* when finished.

So your inequality looks like this:

$$\frac{2x + 5}{x + 1} < \frac{x + 1}{x - 1}$$

We first move the terms on the Right-Hand-Side (RHS) to the left. This results in the inequality below.

$$-\frac{x + 1}{x - 1} + \frac{2x + 5}{x + 1} < 0$$

Next, must sum the terms on the left. Let "sum" denote this expression.

$$\text{sum} = -\frac{x + 1}{x - 1} + \frac{2x + 5}{x + 1}$$

In order to sum these terms, we need to know the Lowest Common Denominator for the sum. The list LD below is the List of Denominators after factoring.

$$\text{LD} = (x - 1, x + 1, 1, 1)$$

Using the List of Denominators above, please type the Lowest Common Denominator (LCD) below. (Recall that the LCD is the product of each appearing factor, where each factor is raised to the highest power to which a that factor appears, respectively).

$$\text{LCD} = (x - 1)(x + 1)$$

Click here \* when finished.

Using the LCD given by you, we add the terms on the LHS to create the "sum" below.

$$\text{sum} = \frac{-(-x - 1)^2 + (x - 1)(2x + 5)}{(x + 1)(x - 1)}$$

$$\text{sum} = \frac{x^2 + x - 6}{(x + 1)(x - 1)}$$

Next, we factor the numerator, if possible.

$$\text{sum} = \frac{(x + 3)(x - 2)}{(x + 1)(x - 1)}$$

Our inequality now becomes:

$$\frac{(x + 3)(x - 2)}{(x + 1)(x - 1)} < 0$$

That is, we are trying to determine what values of x cause our sum to be less than zero.

Now we make a list of boundary points. These are the zeros of each factor in the numerator and the denominator. Please enter these values below. To create a list, just type a comma after each value to add a new value to the list. (This worksheet only allows 4 boundary points!) **THE BOUNDARY POINTS MUST BE SORTED FROM LOW TO HIGH.**

$$\text{boundarypoints} = (-3, -1, 1, 2)$$

Click here \* when finished.

Next we create a table. The boundary points divide the number line into regions. From each of these regions we pick a test point (x). Next we evaluate the "sum" which was the left - hand - side minus the right - hand - side. If the sum is less than zero, then the inequality is true.

For each region, the open interval being tested is (LowerLimit, UpperLimit). The Lower and Upper Limits for each interval are listed in separate columns of the table.

$$M = \begin{pmatrix} \text{Region} & \text{LowerLimit} & \text{UpperLimit} & \text{TestPoint} & \text{sum} & \text{TorF} \\ \text{I} & -\infty & -3 & -4 & \frac{2}{5} & \text{F} \\ \text{II} & -3 & -1 & -2 & -\frac{4}{3} & \text{T} \\ \text{III} & -1 & 1 & 0 & 6 & \text{F} \\ \text{IV} & 1 & 2 & \frac{3}{2} & -\frac{9}{5} & \text{T} \\ \text{V} & 2 & \infty & 3 & \frac{3}{4} & \text{F} \end{pmatrix}$$

The final step is to test the inequality at the Boundary Points.

None of the boundary points are filled below, denoting that they are not part of the solution set. For strict less-than or greater-than problems (without the "or-equal") boundary points are never included. This is because the boundary points make the expression equal to zero (there's the "or-equal" that we don't want) or undefined, neither of which are what we are looking for in this case.

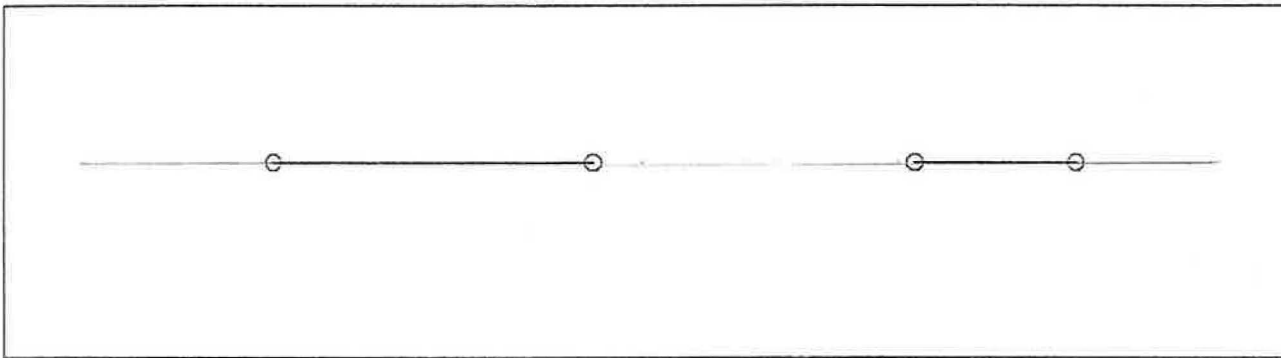

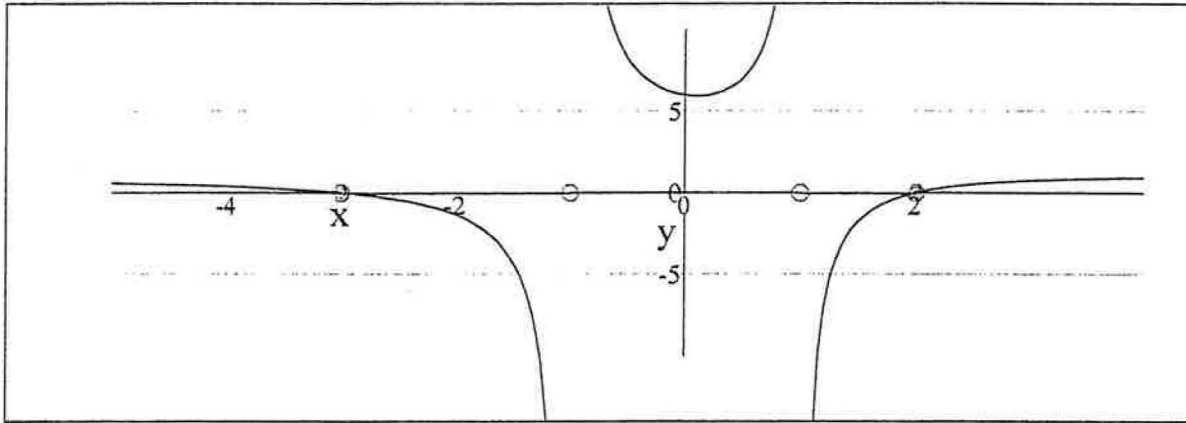

Rational Inequalities: LHS  $\leq$  RHS

Please enter the left - and right - hand sides of your inequality below.

$$\text{LHS} = \frac{2x+5}{x+1}$$

$$\text{RHS} = \frac{x+1}{x-1}$$

Click here \* when finished.

So your inequality looks like this:

$$\frac{2x+5}{x+1} \leq \frac{x+1}{x-1}$$

We first move the terms on the Right - Hand - Side (RHS) to the left. This results in the inequality below.

$$-\frac{x+1}{x-1} + \frac{2x+5}{x+1} \leq 0$$

Next, must sum the terms on the left. Let "sum" denote this expression.

$$\text{sum} = -\frac{x+1}{x-1} + \frac{2x+5}{x+1}$$

In order to sum these terms, we need to know the Lowest Common Denominator for the sum. The list LD below is the List of Denominators after factoring.

$$\text{LD} = (x-1, x+1, 1, 1)$$

Using the List of Denominators above, please type the Lowest Common Denominator (LCD) below. (Recall that the LCD is the product of each appearing factor, where each factor is raised to the highest power to which a that factor appears, respectively).

$$\text{LCD} = (x + 1)(x - 1)$$

Click here \* when finished.

Using the LCD given by you, we add the terms on the LHS to create the "sum" below.

$$\begin{aligned} \text{sum} &= \frac{-(-x - 1)^2 + (x - 1)(2x + 5)}{(x + 1)(x - 1)} \\ \text{sum} &= \frac{x^2 + x - 6}{(x + 1)(x - 1)} \end{aligned}$$

Next, we factor the numerator, if possible.

$$\text{sum} = \frac{(x + 3)(x - 2)}{(x + 1)(x - 1)}$$

Our inequality now becomes:

$$\frac{(x + 3)(x - 2)}{(x + 1)(x - 1)} \leq 0$$

That is, we are trying to determine what values of x cause our sum to be less than or equal to zero.

Now we make a list of boundary points. These are the zeros of each factor in the numerator and the denominator. Please enter these values below. To create a list, just type a comma after each value to add a new value to the list. (This worksheet only allows 4 boundary points!) **THE BOUNDARY POINTS MUST BE SORTED FROM LOW TO HIGH.**

$$\text{boundarypoints} = (-3, -1, 1, 2)$$

Click here \* when finished.

Next we create a table. The boundary points divide the number line into regions. From each of these regions we pick a test point (x). Next we evaluate the "sum" which was the left - hand - side minus the right - hand - side. If the sum is less than zero, then the inequality is true.

For each region, the open interval being tested is (LowerLimit, UpperLimit). The Lower and Upper Limits for each interval are listed in separate columns of the table.

$$M = \begin{pmatrix} \text{Region} & \text{LowerLimit} & \text{UpperLimit} & \text{TestPoint} & \text{sum} & \text{TorF} \\ \text{I} & -\infty & -3 & -4 & \frac{2}{5} & \text{F} \\ \text{II} & -3 & -1 & -2 & -\frac{4}{3} & \text{T} \\ \text{III} & -1 & 1 & 0 & 6 & \text{F} \\ \text{IV} & 1 & 2 & \frac{3}{2} & -\frac{9}{5} & \text{T} \\ \text{V} & 2 & \infty & 3 & \frac{3}{4} & \text{F} \end{pmatrix}$$

The final step is to test the inequality at the Boundary Points. In this case, the inequality is true whenever  $\text{sum} \leq 0$ , and this will happen for boundary points that make the numerator of "sum" equal to zero.

The boundary points which are filled in the graph below are part of the solution set

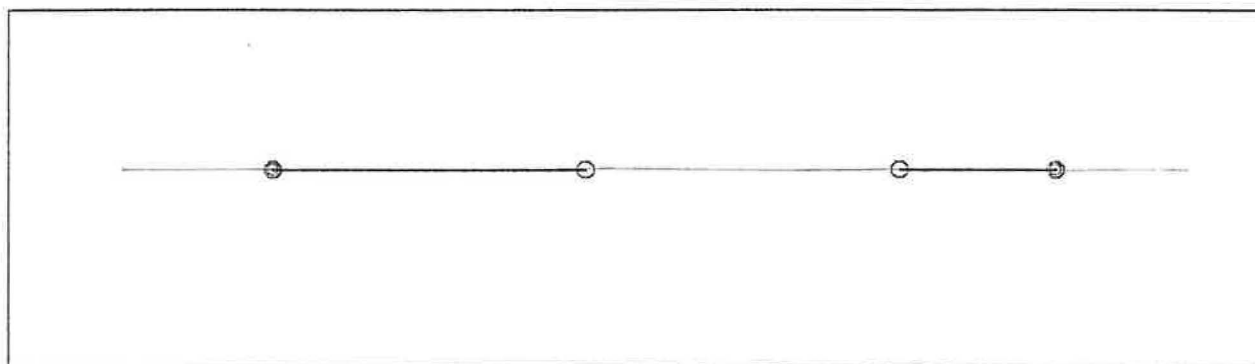

## Graphing Exponential Functions

Our most elementary form of an exponential graph will be  $y = b^x$  where  $b > 0$  and  $b \neq 1$ . There are two basic cases we must learn. The first case is where  $b > 1$  and the second case is where  $0 < b < 1$ . The graphs of these two cases are below

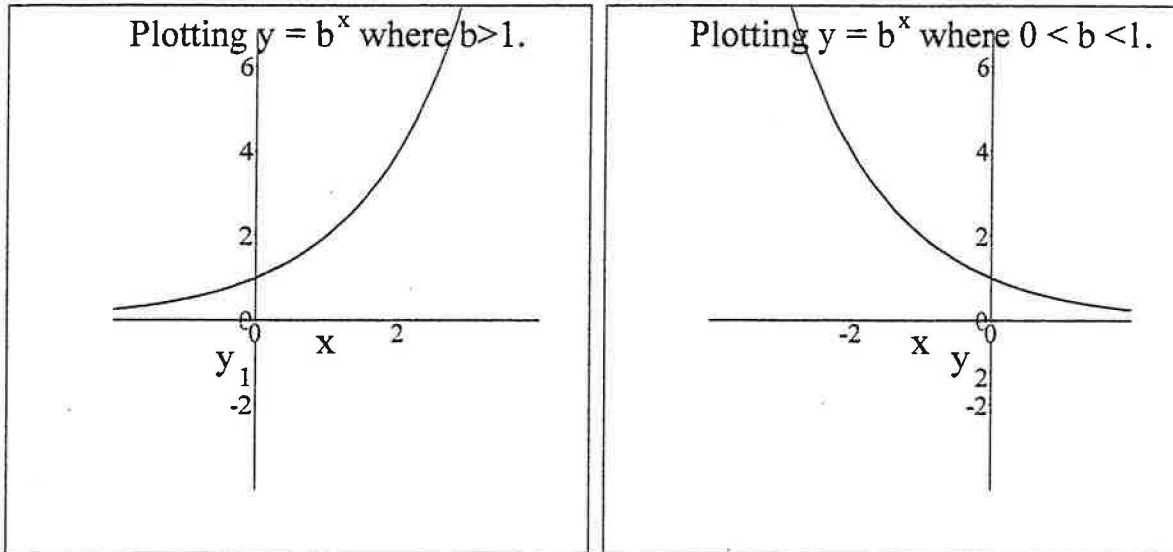

### Graphing your own function...

To type an exponent, you need to press the ^ key. Try plotting your own exponential function below. Use the knife and rocket icons to zoom in and out, respectively. Also, you can grab the graph by dragging with your mouse to shift right, left, up or down.

$$y = -\frac{1}{2} \cdot 3^{x-1} + 1$$

Adjust the values of the minimum and maximum x and y values as needed. These define the size and position of the viewing window.

$$x_{\min} = -4 \quad x_{\max} = 4 \quad y_{\min} = -6 \quad y_{\max} = 3$$

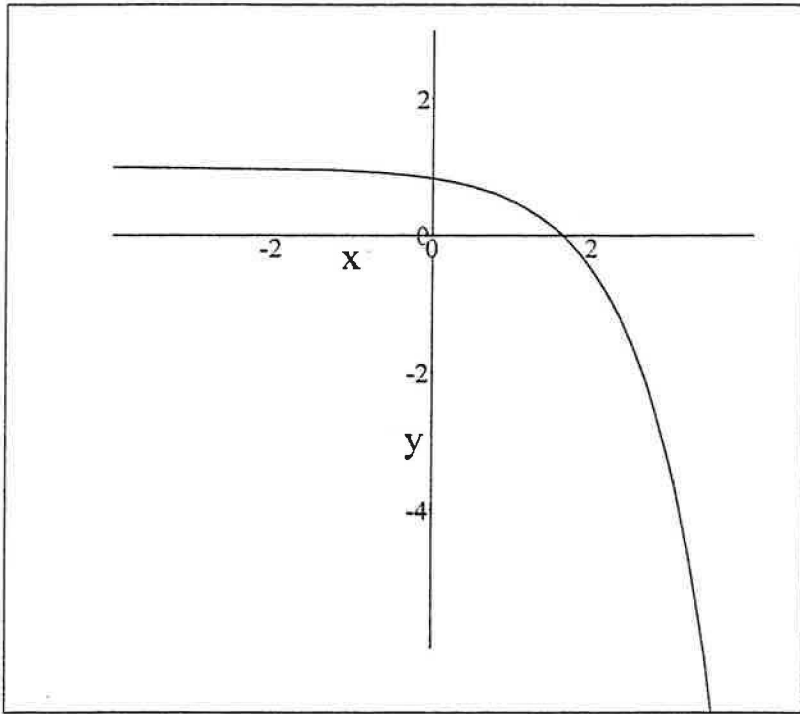

Copyright July 2000 by Scott Guth  
Mt. San Antonio College

## Graphing Logarithmic Functions

Our most elementary form of a logarithm graph will be  $y = \log_b(x)$  where  $b > 0$  and  $b \neq 1$ . There are two basic cases we must learn. The first case is where  $b > 1$  and the second case is where  $0 < b < 1$ . The graphs of these two cases are below

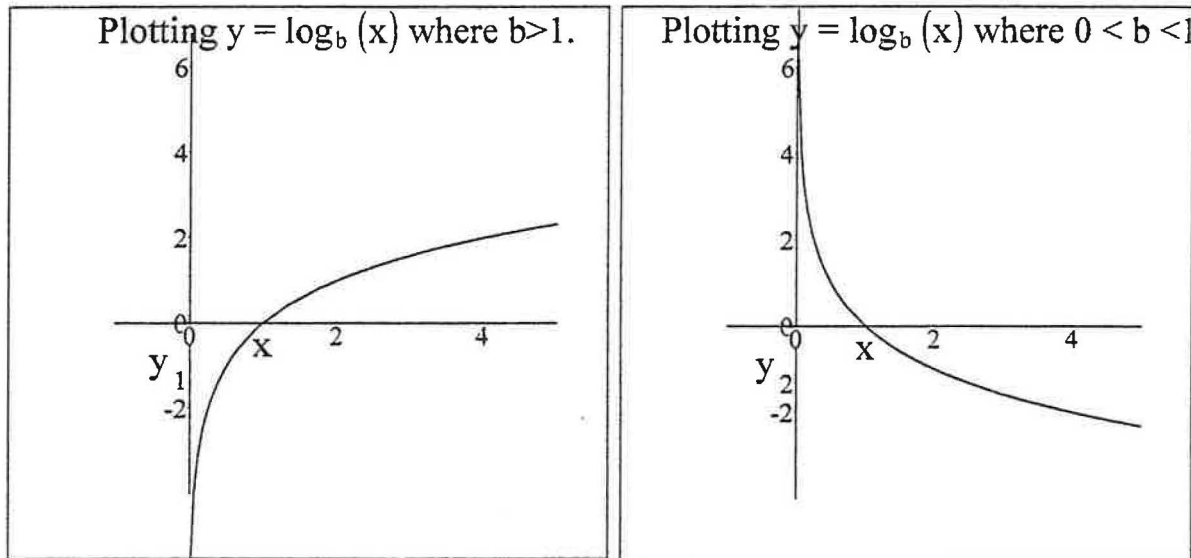

### Plotting your own function...

Typing a logarithm is only slightly tricky. To begin, just type "y = log" then type an "underbar" character (hold shift and press the minus key) to cause the cursor to go to a subscript position, type the base, then type a left parenthesis. Enter the expression inside the logarithm. Feel free to change the equation below to graph any logarithmic function.

Use the knife and rocket icons to zoom in and out, respectively. Also, you can grab the graph by dragging with your mouse to shift right, left, up or down.

$$y = -\frac{1}{2} \log_3(x-1) - 3$$

Adjust the values of the minimum and maximum x and y values as needed. These define the size and position of the viewing window.

$$x_{\min} = -0.5 \quad x_{\max} = 3 \quad y_{\min} = -4 \quad y_{\max} = 1$$

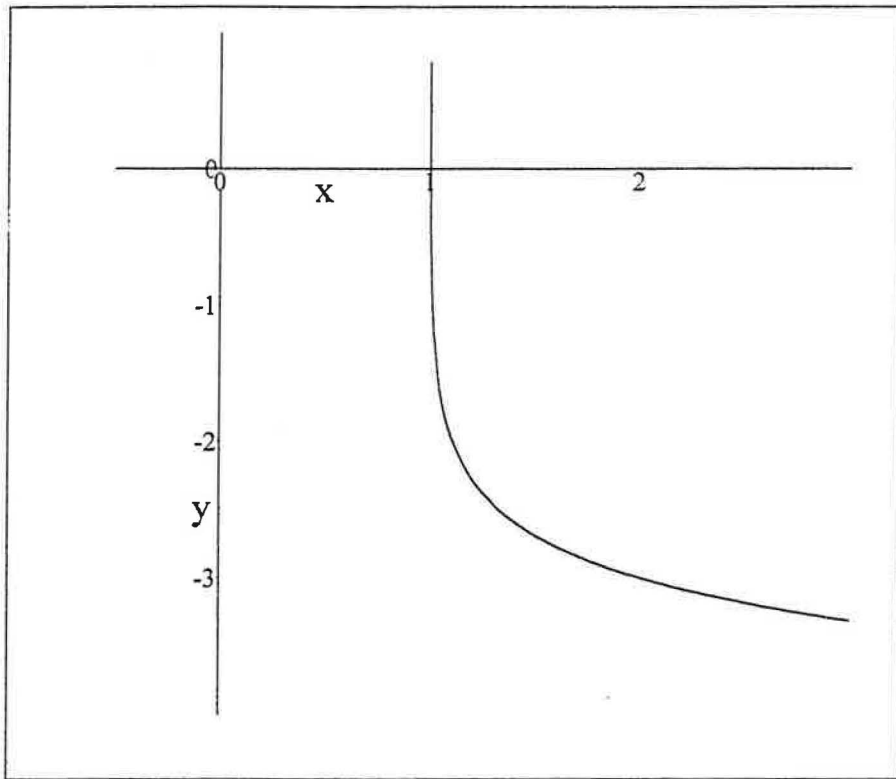

Copyright July 2000 by Scott Guth  
Mt. San Antonio College

## Conic Sections: Parabolas (Vertically or Horizontally Oriented)

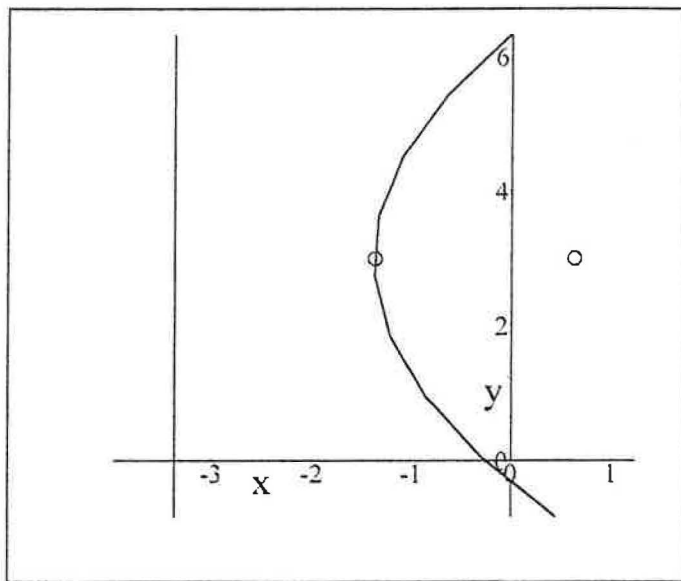

Please enter the left and right hand sides (LHS and RHS) of your equation below. This derivation will look best if you clear fractions in your equation first.

$$\text{LHS} = y^2 - 8x$$

$$\text{RHS} = 6y + 2$$

Click here \* when done.

So your equation looks like this:

$$-8x + y^2 = 6y + 2$$

We now proceed to complete the square so that your equation looks like this:

$$(y - k)^2 = 4p(x - h)$$

In this form, we know the coordinates of the vertex  $(h, k)$ , and  $p$ , the distance from the vertex to the focus and directrix.

If you entered your equation with the square already completed, please disregard this part of the discussion.

$$y^2 - 6y - 2 = 8x$$

$$y^2 - 6y - 2 = 8x$$

$$1(y^2 - 6y + 9) - 2 - 9 = 8x$$

$$1(y - 3)^2 - 11 = 8x$$



$$(y - 3)^2 = 8x + 11$$

$$(y - 3)^2 = 8\left(x + \frac{11}{8}\right)$$

$$(y - 3)^2 = 8\left(x + \frac{11}{8}\right)$$

$$(y - 3)^2 = 4 \cdot 2\left(x + \frac{11}{8}\right)$$

From this form we learn the coordinates of the vertex, and the value of p:

$$\text{vertex} = \left(-\frac{11}{8}, 3\right)$$

$$p = 2$$

Next, using the vertex and p, we can find the location of the focus...

$$\text{focus} = \left(\frac{5}{8}, 3\right)$$

... and the equation of the directrix:

$$x = -\frac{27}{8}$$

We now can plot the parabola. The focus and vertex are plotted red, and the black line is the directrix. The coordinate axes are in blue.

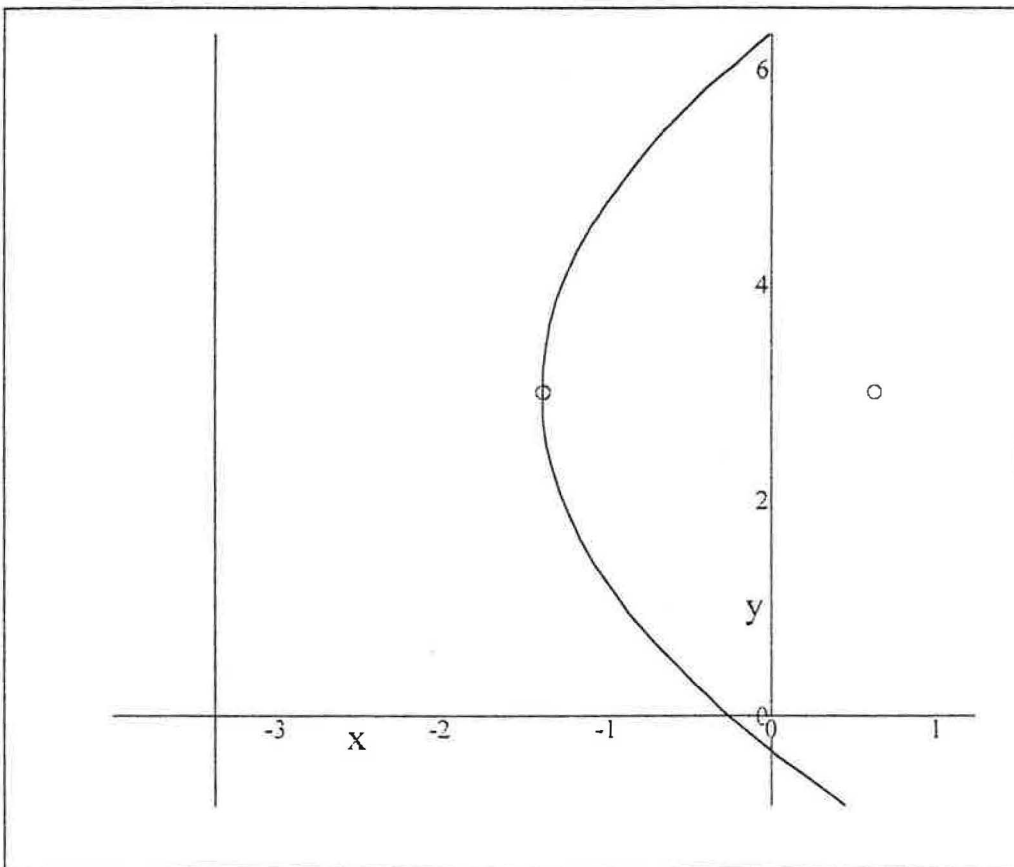

## Graphing Conic Sections: Ellipses, Hyperbolas and Circles

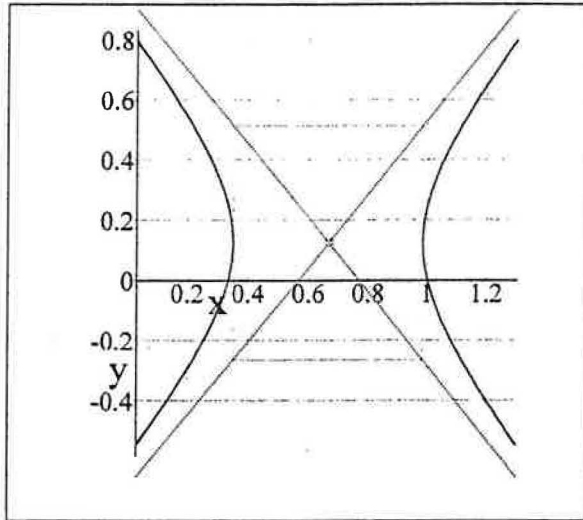

This tutorial will help you learn the steps for plotting ellipses and hyperbolas, based on equations that you supply. It is assumed that you are familiar with the process of completing the square for quadratics.

If the equation you submit represents a circle, it will be treated as an ellipse, but you can identify it as a circle if the values for a and b given below are equal.

Please enter the left and right hand sides (LHS and RHS) of your equation below. This derivation will look best if you clear fractions in your equation first.

$$\text{LHS} = 4y^2 + 8x$$

$$\text{RHS} = 6x^2 + 2 + y$$

Click here \* when done.

So your equation looks like this:

$$8x + 4y^2 = 6x^2 + y + 2$$

First, moving all terms to the left side gives us:

$$-6x^2 + 8x + 4y^2 - y - 2 = 0$$

And based on these coefficients, we have classified this conic section:  
graph = hyperbola

We will now proceed to complete the square on both x and y. If the equation you entered has both squares completed already, just ignore this development.

$$\begin{aligned}
 (-6)\left(x^2 - \frac{4}{3}x\right) + 4\left(y^2 - \frac{1}{4}y\right) &= 2 \\
 (-6)\left(x^2 - \frac{4}{3}x + \frac{4}{9}\right) + 4\left(y^2 - \frac{1}{4}y + \frac{1}{64}\right) &= -\frac{8}{3} + \frac{1}{16} + 2 \\
 (-6)\left(x - \frac{2}{3}\right)^2 + 4\left(y - \frac{1}{8}\right)^2 &= -\frac{29}{48} \\
 \frac{(-6)\left(x - \frac{2}{3}\right)^2}{-\frac{29}{48}} + \frac{4\left(y - \frac{1}{8}\right)^2}{-\frac{29}{48}} &= 1 \\
 \frac{\left(x - \frac{2}{3}\right)^2}{\left(-\frac{1}{6}\right)\left(-\frac{29}{48}\right)} + \frac{\left(y - \frac{1}{8}\right)^2}{\frac{1}{4}\left(-\frac{29}{48}\right)} &= 1 \\
 \frac{\left(x - \frac{2}{3}\right)^2}{\frac{29}{288}} + \frac{\left(y - \frac{1}{8}\right)^2}{-\frac{29}{192}} &= 1
 \end{aligned}$$

This equation can be put into the form:

$$\frac{(x - h)^2}{a^2} - \frac{(y - k)^2}{b^2} = 1$$

Where a and b are simplified below.

$$a = \frac{1}{24}\sqrt{58} \quad b = \frac{1}{24}\sqrt{87}$$

If the equation you entered represents an ellipse, then recall that  $a > b$ .

So the final result is:

$$\frac{\left(x - \frac{2}{3}\right)^2}{\left(\frac{1}{24}\sqrt{58}\right)^2} - \frac{\left(y - \frac{1}{8}\right)^2}{\left(\frac{1}{24}\sqrt{87}\right)^2} = 1$$

From this we have the coordinates of the center:

$$\text{center} = \left(\frac{2}{3}, \frac{1}{8}\right)$$

Now we are able to draw the graph of the equation which you provided. Check the discussion below the graph for details on how this graph is drawn.

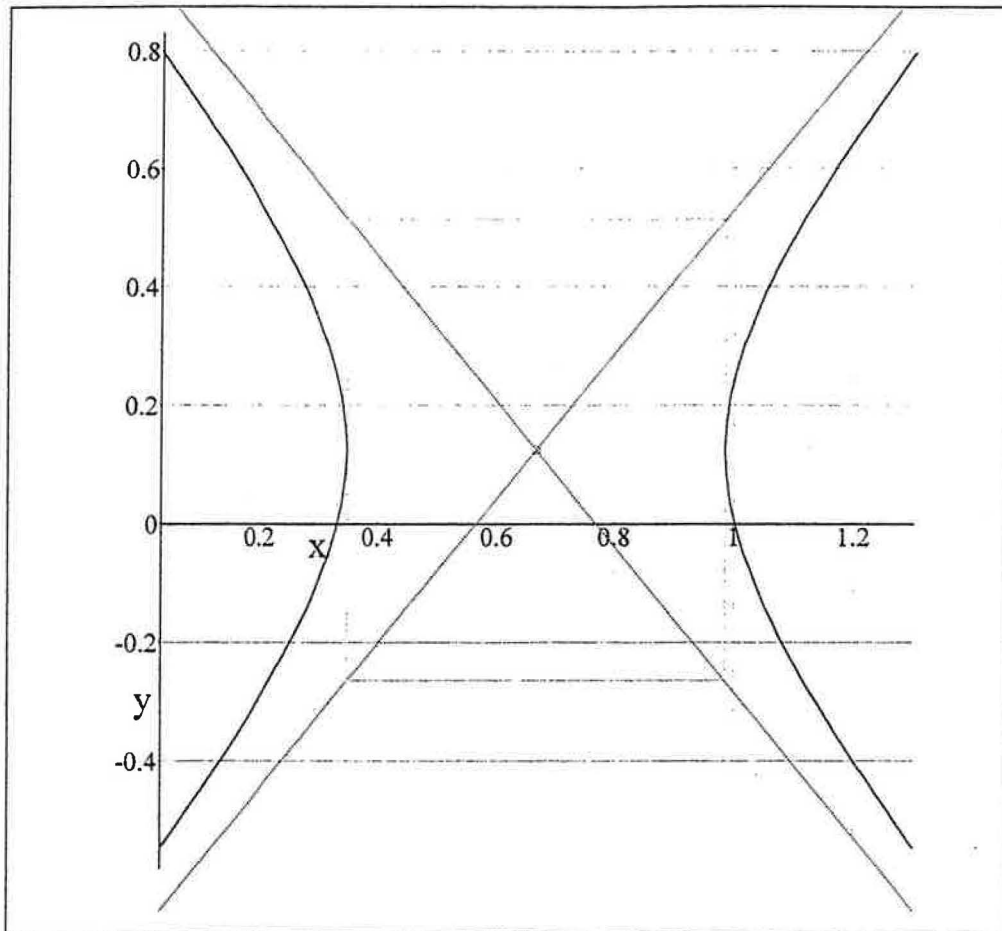

Plotting ellipses whose equations look like  $\frac{(x - h)^2}{a^2} + \frac{(y - k)^2}{b^2} = 1$

Here it is important to note that  $a > b$ .

This ellipse is horizontally oriented, and is centered at  $(h,k)$ .

Draw a box centered at  $(h,k)$  with a dotted line. The width of the box is  $2a$  and the height is  $2b$ . Draw an ellipse inside the box neatly, touching all four sides at the center of each side, and you're done.

Plotting ellipses whose equations look like  $\frac{(x - h)^2}{b^2} + \frac{(y - k)^2}{a^2} = 1$

Again, it is important to note that  $a > b$ , but this time note that the positions of  $a$  and  $b$  have changed from the previous equation.

This ellipse is vertically oriented, and is centered at  $(h,k)$ .

Draw a box centered at  $(h,k)$  with a dotted line. The width of the box is  $2b$  and the height is  $2a$ . Draw an ellipse inside the box neatly, touching all four sides at the center of each side, and you're done.

Plotting hyperbolas whose equations look like  $\frac{(x - h)^2}{a^2} - \frac{(y - k)^2}{b^2} = 1$

This hyperbola opens to the left and right, and is centered at  $(h,k)$ .

Draw a box centered at  $(h,k)$  with a dotted line. The width of the box is  $2a$  and the height is  $2b$ . Next draw two diagonal dotted lines through the corners of the box. The hyperbola should touch the left and right sides of the boxes and approach the asymptotes as they go away from the box.

Plotting hyperbolas whose equations look like  $\frac{(y - k)^2}{b^2} - \frac{(x - h)^2}{a^2} = 1$

This hyperbola opens to the upward and downward, and is centered at  $(h,k)$ .

Draw a box centered at  $(h,k)$  with a dotted line. The width of the box is  $2a$  and the height is  $2b$ . Next draw two diagonal dotted lines through the corners of the box. The hyperbola should touch the top and bottom of the boxes and approach the asymptotes as they go away from the box.

## Two Dimensional Plotter

Enter the limits on x and y below. These define the minimum and maximum x and y values to be displayed on your graph.

$$x_{\min} = -4 \quad x_{\max} = 4 \quad y_{\min} = -3 \quad y_{\max} = 3$$

Enter an equation in x and y below.

$$\frac{x^2}{9} + \frac{y^2}{4} = 1$$

You may add another equation to plot below.

$$x = y^2$$

Here is the plot of your equation.

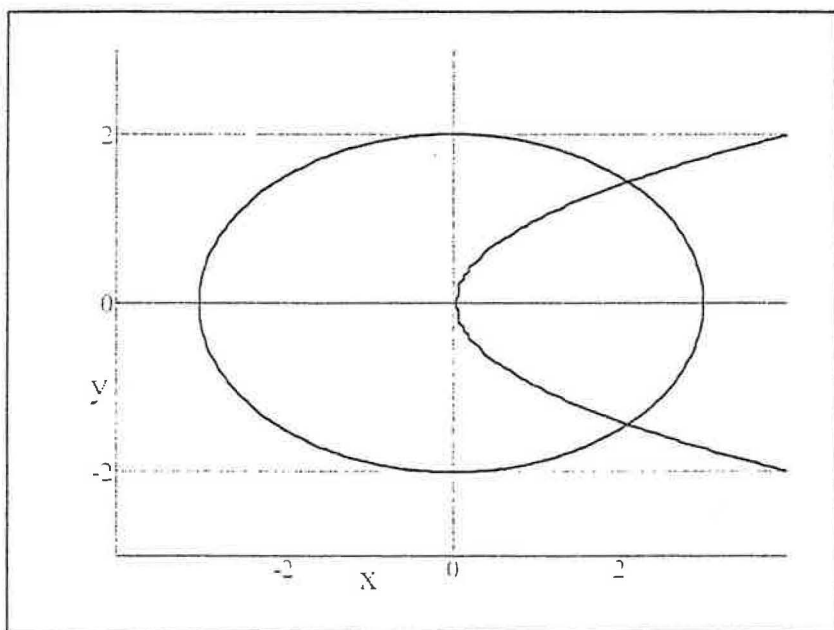

Copyright July 2000 by Scott Guth  
Mt. San Antonio College

## Parametric Equations Plotter

Enter  $x$  and  $y$  below as functions of  $t$ .

$$x(t) = 2 \cos(4t)$$

$$y(t) = 3 \cos(5t)$$

Next, enter the limits on  $t$  below.

$$t_{\min} = 0$$

$$t_{\max} = \pi$$

And here is the plot of your function.

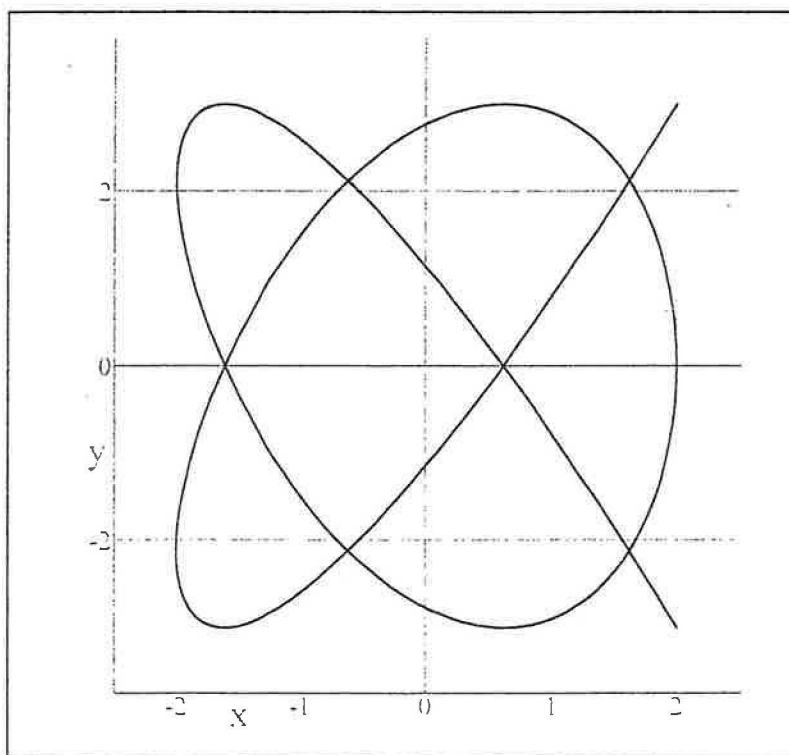

## Two Dimensional Vector Valued Functions: Velocity and Acceleration

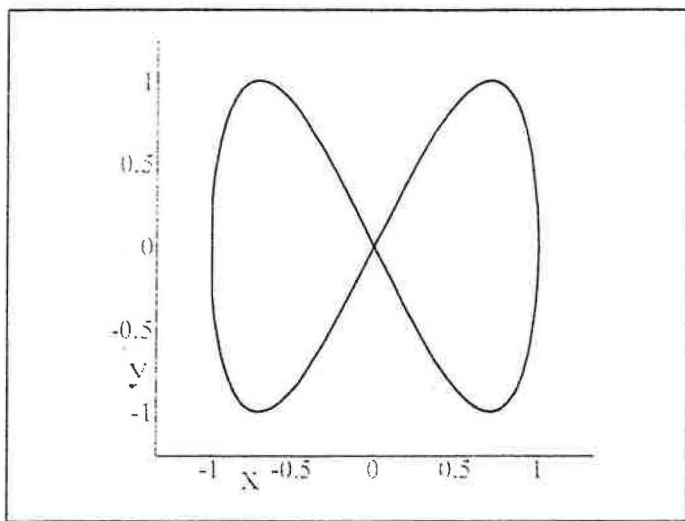

Please enter your two dimensional vector-valued function  $r(t)$  below.

$$r(t) = (\cos[t], \sin[2t])$$

Click here \* when done.

Please enter limits for t:

$$t_{\min} = 0$$

$$t_{\max} = 2\pi$$

The velocity and acceleration are given here:

$$v(t) = (-\sin[t], 2\cos[2t]) \quad \text{Expand}$$

$$a(t) = (-\cos[t], -4\sin[2t]) \quad \text{Expand}$$

The lengths of the vectors will be divided by "scale". Change this value to make the vectors appear longer or shorter.

$$\text{scale} = 3$$

Click here \* to graph the function.

The graph below has a tangent velocity vector in red, plus the acceleration vector in red. The blue vectors are the tangential and normal components of acceleration. Click on the graph to animate the vectors.



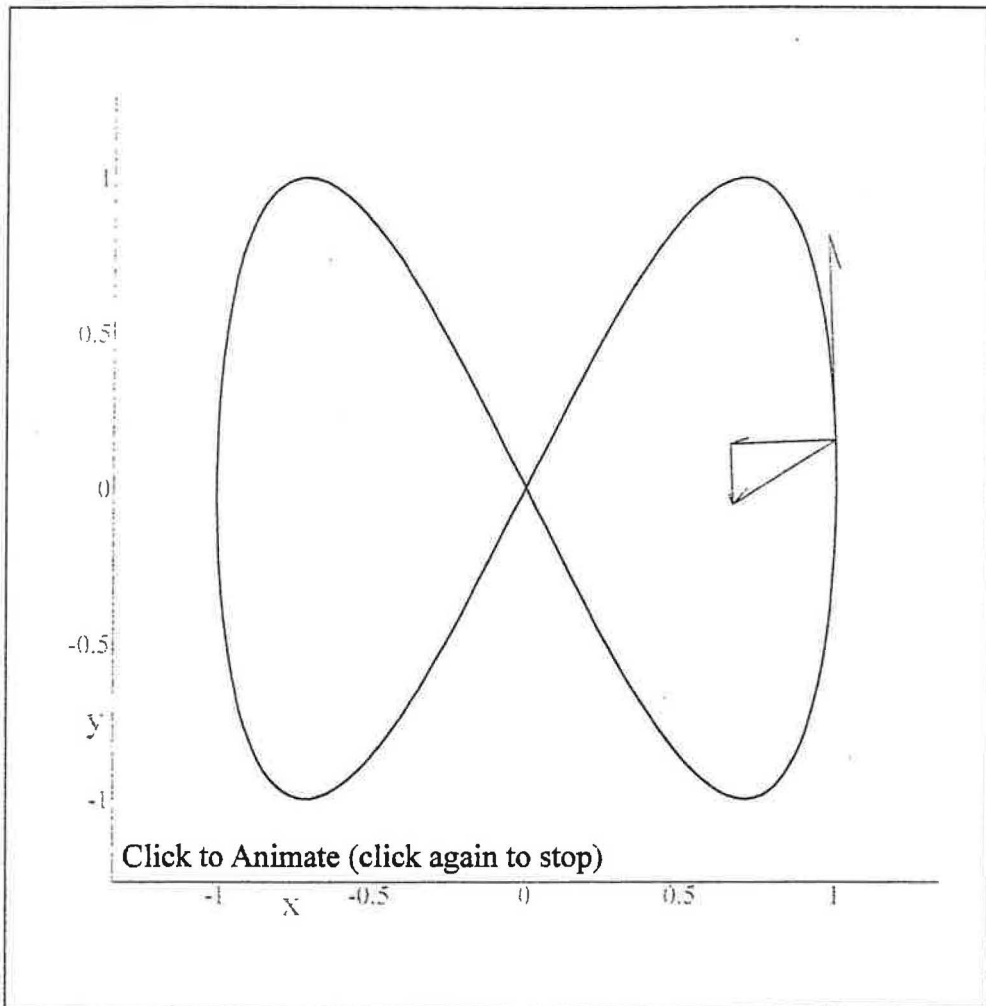

Animate this graph for  $t_z = t_{min} \dots t_{max}$  in steps of  $\frac{1}{80} t_{max} - \frac{1}{80} t_{min}$  for a total of 80 frames in a cycle at 10 frames/second.

Copyright July 2000 by Scott Guth  
Mt. San Antonio College

## 3D Spacecurves with Vector Fields

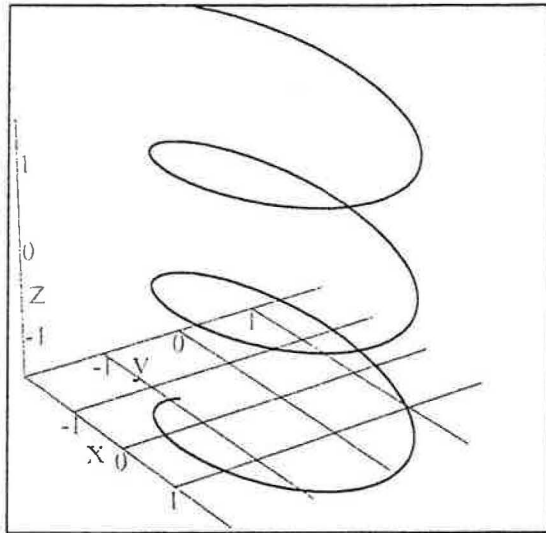

Please enter your vector - valued function below as a function of  $t$ .  
Separate the  $x$ ,  $y$ , and  $z$  components by commas.

$$r(t) = \left( 2 \cos[t], \sin[t], \frac{t}{4} \right)$$

Now we need limits on the parameter  $t$ .

$$t_{\min} = -3\pi \quad t_{\max} = 3\pi$$

Finally we need limits on  $x$ ,  $y$ , and  $z$ . These are used only to define the size of the window. If your surface doesn't fit in the plot window, widen the range on these limits.

$$\begin{aligned} x_{\min} &= -2 & x_{\max} &= 2 \\ y_{\min} &= -2 & y_{\max} &= 2 \\ z_{\min} &= -1.5 & z_{\max} &= 1.5 \end{aligned}$$

Click here \* to draw your graph.

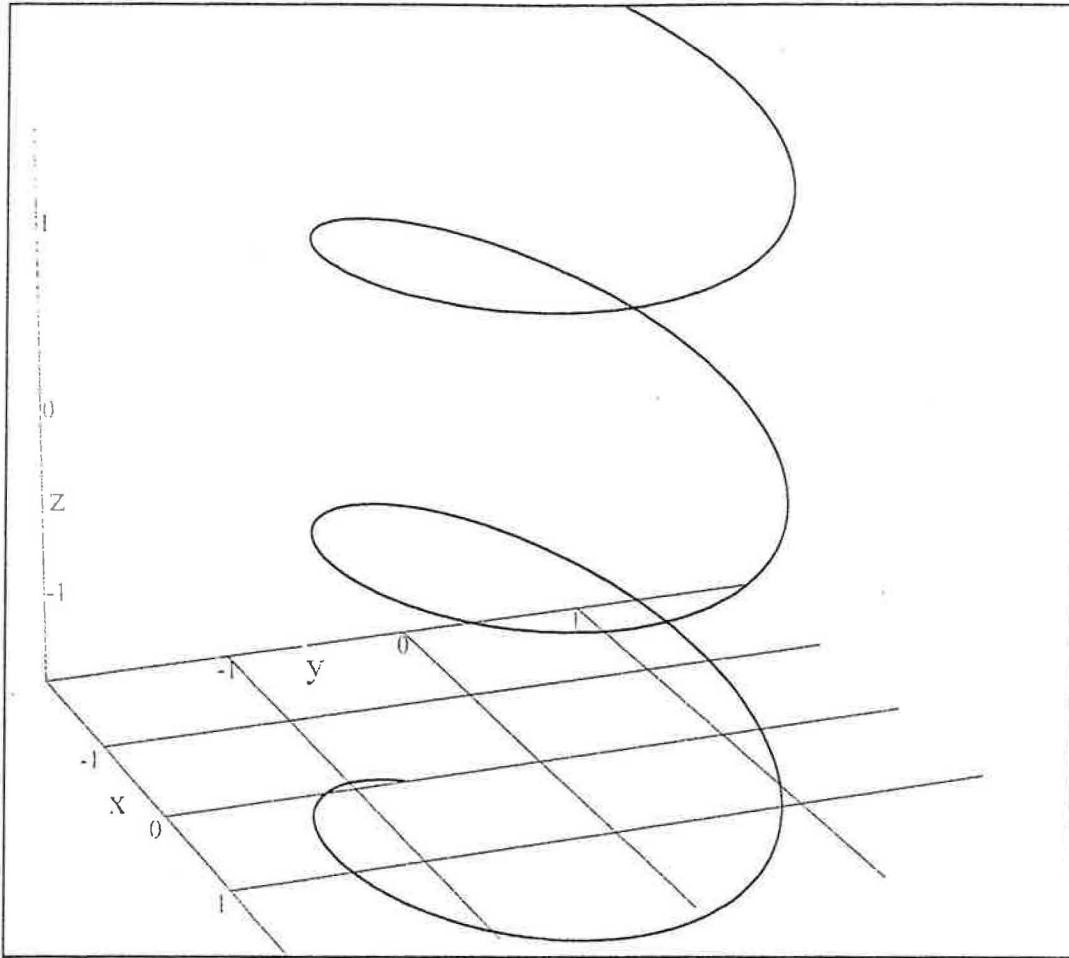

Copyright July 2000 by Scott Guth  
Mt. San Antonio College

## 3D Spacecurves with Vector Fields

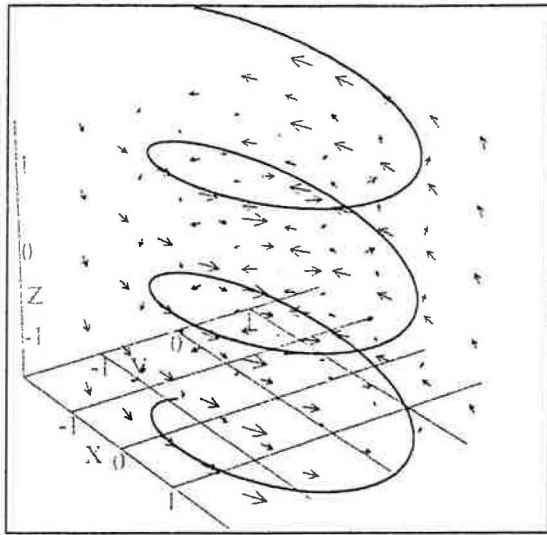

Please enter your vector - valued function below as a function of  $t$ .  
Separate the  $x$ ,  $y$ , and  $z$  components by commas.

$$\mathbf{r}(t) = \left( 2 \cos[t], \sin[t], \frac{t}{4} \right)$$

Next enter your vector field:

$$\mathbf{F}(x, y, z) = \left( -2y, x, \frac{z}{4} \right)$$

Click here \* when done.

Now we need limits on the parameter  $t$ .

$$t_{\min} = -3\pi \quad t_{\max} = 3\pi$$

Click here \* when done.

Here we compute the work done by the force implied by this vector field on the object which is traveling along this spacecurve.

$$\text{work} = \int_{t_{\min}}^{t_{\max}} \mathbf{F}(x[t], y[t], z[t]) \cdot d\mathbf{r}(t)$$

$$\text{work} = \int_{-3\pi}^{3\pi} \mathbf{F}\left(2 \cos[t], \sin[t], \frac{1}{4}t\right) \cdot d\left(2 \cos[t], \sin[t], \frac{1}{4}t\right)$$

$$\text{work} = \int_{-3\pi}^{3\pi} \left(-2 \sin[t], 2 \cos[t], \frac{1}{16}t\right) \cdot d\left(2 \cos[t], \sin[t], \frac{1}{4}t\right)$$

$$\text{work} = \int_{-3\pi}^{3\pi} \left(-2 \sin[t], 2 \cos[t], \frac{1}{16}t\right) \cdot \left(-2 \sin[t] dt, \cos[t] dt, \frac{1}{4} dt\right)$$

$$\text{work} = \int_{-3\pi}^{3\pi} 2(\cos[t])^2 dt + 4(\sin[t])^2 dt + \frac{1}{64}t dt$$

$$\text{work} = 18\pi$$

Finally we need limits on x, y, and z. These are used only to define the size of the window. If your surface doesn't fit in the plot window, widen the range on these limits.

$$x_{\min} = -2 \quad x_{\max} = 2$$

$$y_{\min} = -2 \quad y_{\max} = 2$$

$$z_{\min} = -1.5 \quad z_{\max} = 1.5$$

Click here \* to draw your graph.

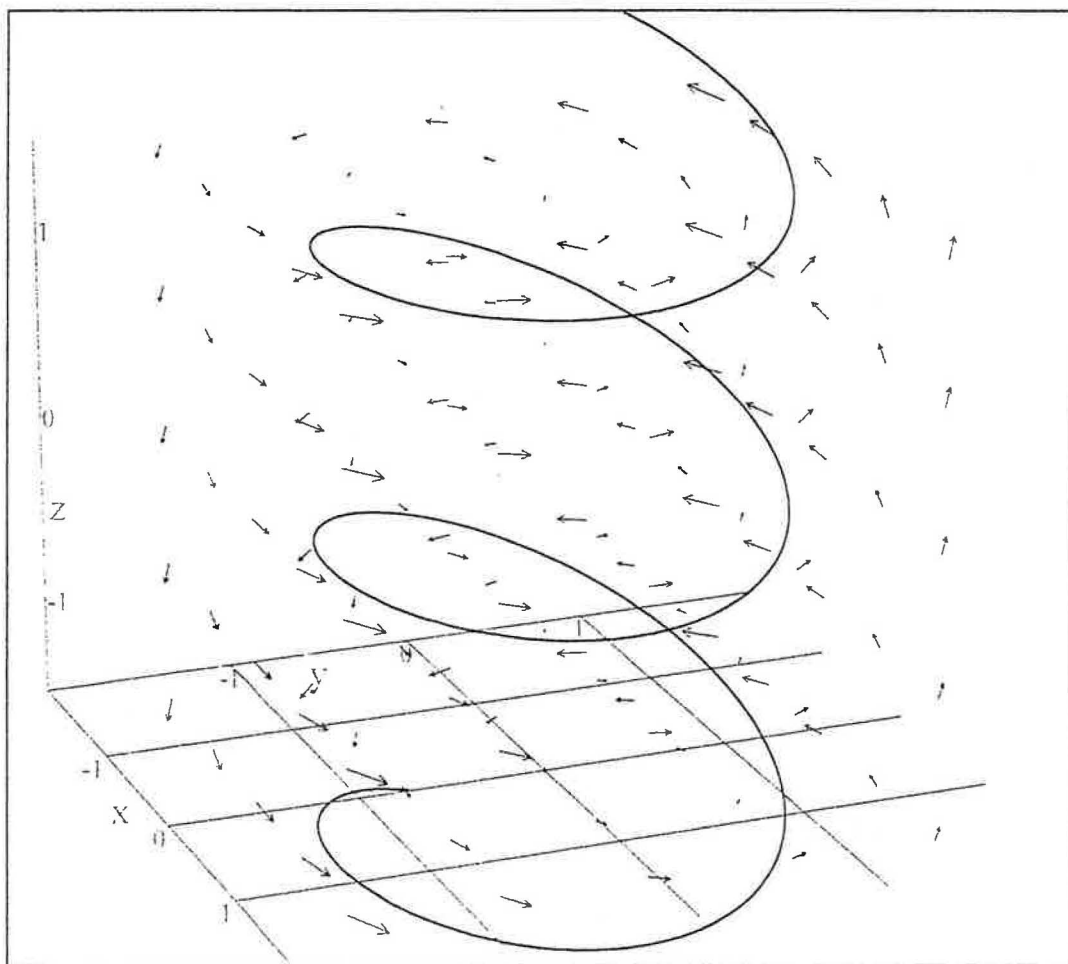

## 3D Vector Valued Functions: Velocity Vectors

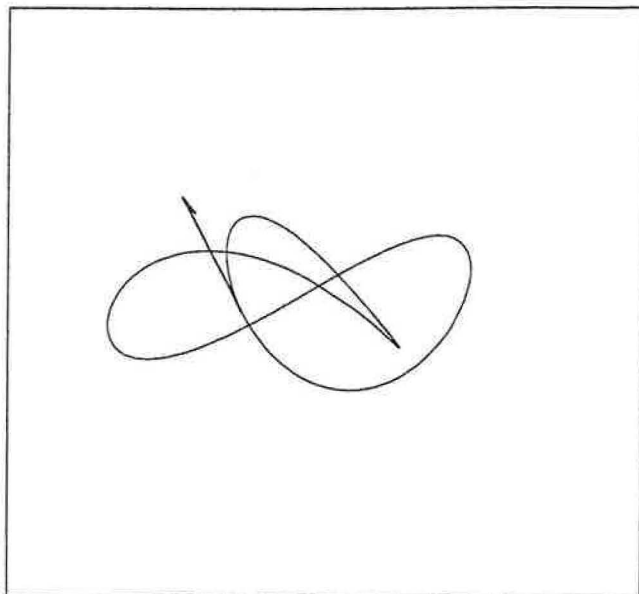

Please enter your 3D vector valued function below, use commas to separate the x y and z components of the function.

$$r(t) = (0.5 \cos[t] + \cos[2t], \sin[2t] - 0.5 \sin[t], 0.5 \sin[3t] + 0.5)$$

Click here \* when finished.

Now we compute the velocity and acceleration vectors from your function.

$$v(t) = (-0.5 \sin[t] - 2 \sin[2t], -0.5 \cos[t] + 2 \cos[2t], 1.5 \cos[3t]) \quad \text{Expand}$$

$$a(t) = (-0.5 \cos[t] - 4 \cos[2t], 0.5 \sin[t] - 4 \sin[2t], -4.5 \sin[3t]) \quad \text{Expand}$$

Enter the max and min values on the parameter t below. (Type 'p' to enter  $\pi$ ).

$$t_{\min} = 0$$

$$t_{\max} = 2\pi$$

The lengths of the vectors will be divided by "scale". Change this value to make the vectors appear longer or shorter.

$$\text{scale} = 2$$

Finally, you can enter the number of frames in the animation. Higher values make the animation smoother.

$$\text{frames} = 40$$

Click here \* to graph the function.

The graph is below. You can click and drag the graph to change the orientation.  
Click once on the graph to animate the velocity vector.

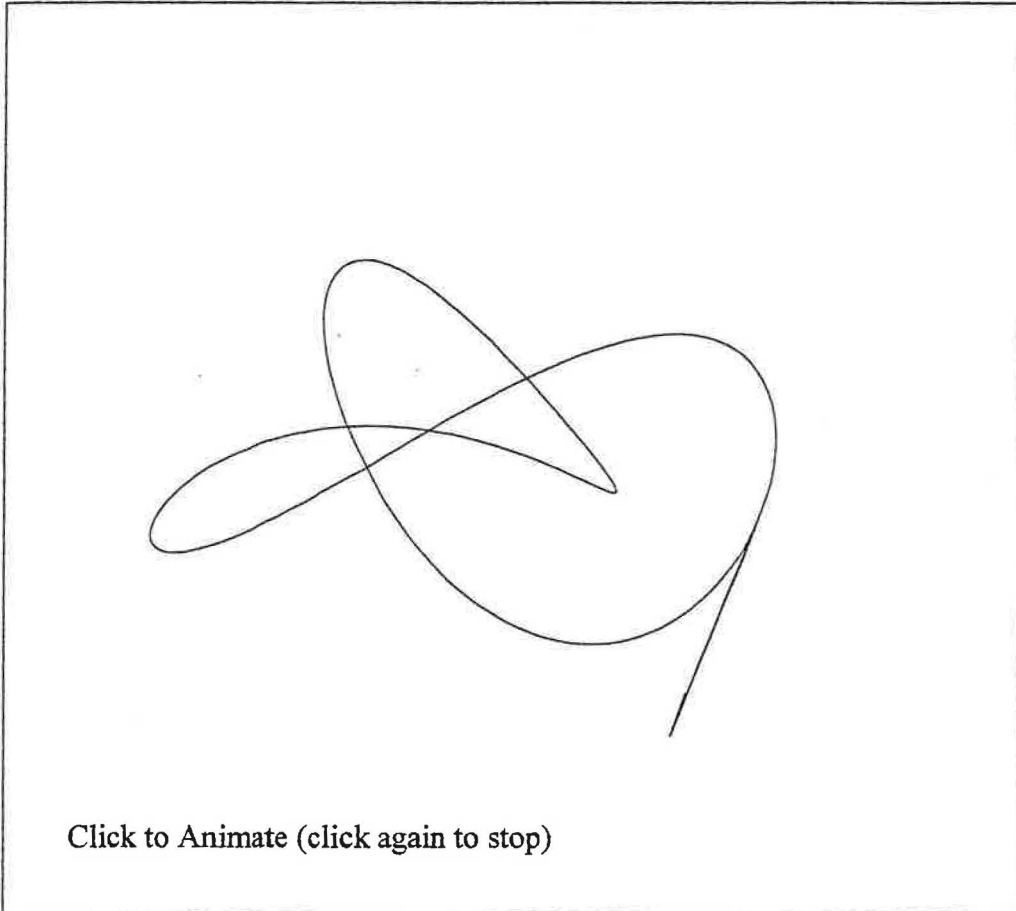

Animate this graph for  $t_z = t_{\min} \dots t_{\max}$  in steps of  $\frac{t_{\max}}{\text{frames}} - \frac{t_{\min}}{\text{frames}}$   
for a total of frames frames in a cycle at 10 frames/second.

## 3D Vector Valued Functions: Acceleration Vectors

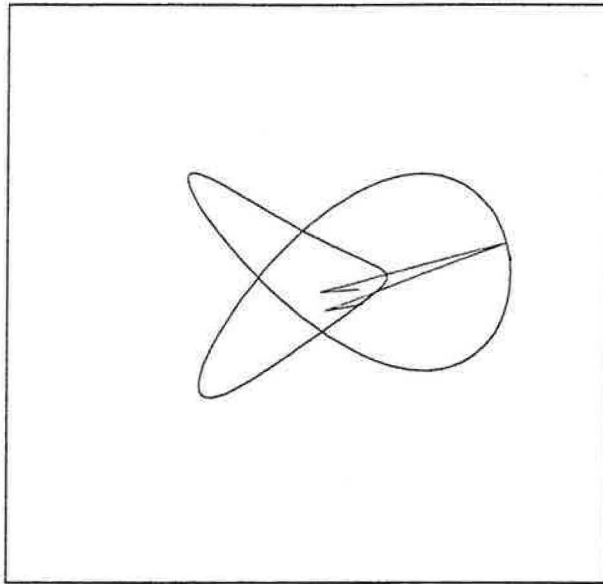

Please enter your 3D vector valued function below, use commas to separate the x y and z components of the function.

$$r(t) = (0.5 \cos[t] + \cos[2t], \sin[2t] - 0.5 \sin[t], 0.5 \sin[3t] + 0.5)$$

Click here \* when finished.

Now we compute the velocity and acceleration vectors from your function.

$$v(t) = (-0.5 \sin[t] - 2 \sin[2t], -0.5 \cos[t] + 2 \cos[2t], 1.5 \cos[3t]) \quad \text{Expand}$$

$$a(t) = (-0.5 \cos[t] - 4 \cos[2t], 0.5 \sin[t] - 4 \sin[2t], -4.5 \sin[3t]) \quad \text{Expand}$$

Enter the max and min values on the parameter t below. (Type 'p' to enter  $\pi$ ).

$$t_{\min} = 0$$

$$t_{\max} = 2\pi$$

The lengths of the vectors will be divided by "scale". Change this value to make the vectors appear longer or shorter.

$$\text{scale} = 4$$

Finally, you can enter the number of frames in the animation. Higher values make the animation smoother.

$$\text{frames} = 80$$



The graph is below. You can click and drag the graph to change the orientation. Click once on the graph to animate the velocity vector.

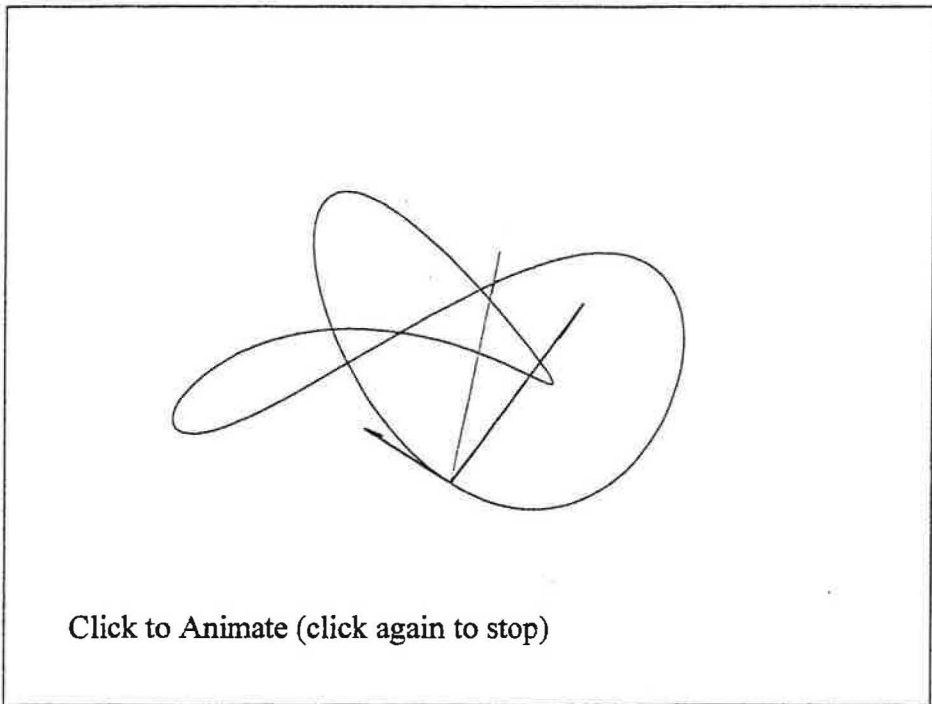

Animate this graph for  $t_z = t_{\min} \dots t_{\max}$  in steps of  $\frac{t_{\max}}{\text{frames}} - \frac{t_{\min}}{\text{frames}}$  for a total of frames frames  at .

Copyright July 2000 by Scott Guth  
Mt. San Antonio College

## 3D Vector Valued Functions: Unit Tangent, and Normal Vectors

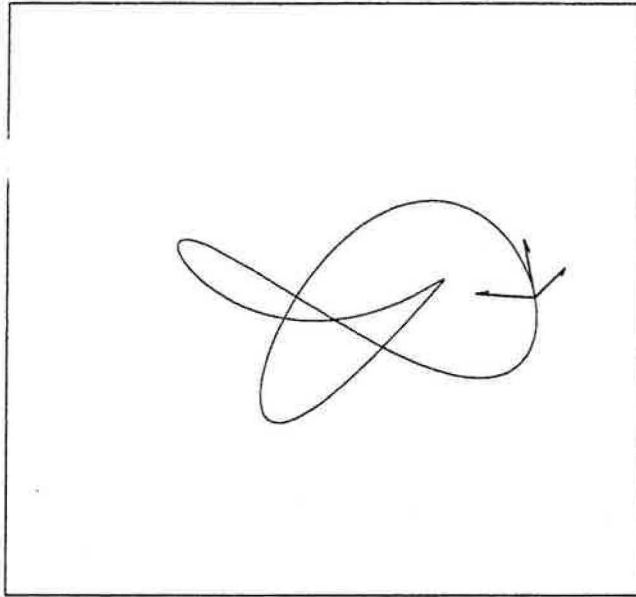

Please enter your 3D vector valued function below, use commas to separate the x y and z components of the function.

$$r(t) = (0.5 \cos[t] + \cos[2t], \sin[2t] - 0.5 \sin[t], 0.5 \sin[3t] + 0.5)$$

Click here \* when finished.

Now we compute the velocity and acceleration vectors from your function.

$$v(t) = (-0.5 \sin[t] - 2 \sin[2t], -0.5 \cos[t] + 2 \cos[2t], 1.5 \cos[3t])$$
$$a(t) = (-0.5 \cos[t] - 4 \cos[2t], 0.5 \sin[t] - 4 \sin[2t], -4.5 \sin[3t])$$

Enter the max and min values on the parameter t below. (Type 'p' to enter  $\pi$ ).

$$t_{\max} = 2\pi$$

$$t_{\min} = 0$$

The lengths of the vectors will be divided by "scale". Change this value to make the vectors appear longer or shorter.

$$\text{scale} = 2$$

Finally, you can enter the number of frames in the animation. Higher values make the animation smoother.

frames = 20

Click here \* to graph the function.

The graph is below. You can click and drag the graph to change the orientation. Click once on the graph to animate the velocity vector.

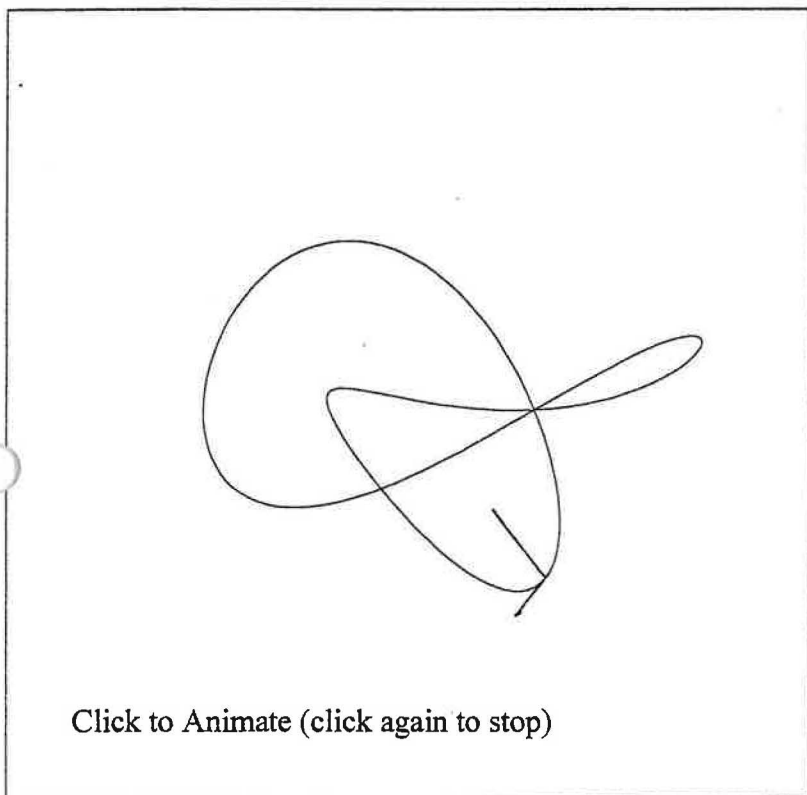

Animate this graph for  $t_z = t_{min} \dots t_{max}$  in steps of  $\frac{t_{max}}{\text{frames}} - \frac{t_{min}}{\text{frames}}$  for a total of frames frames in a cycle at 6 frames/second.

## 3D Vector Valued Functions: Unit Tangent, Normal and Binormal Vectors

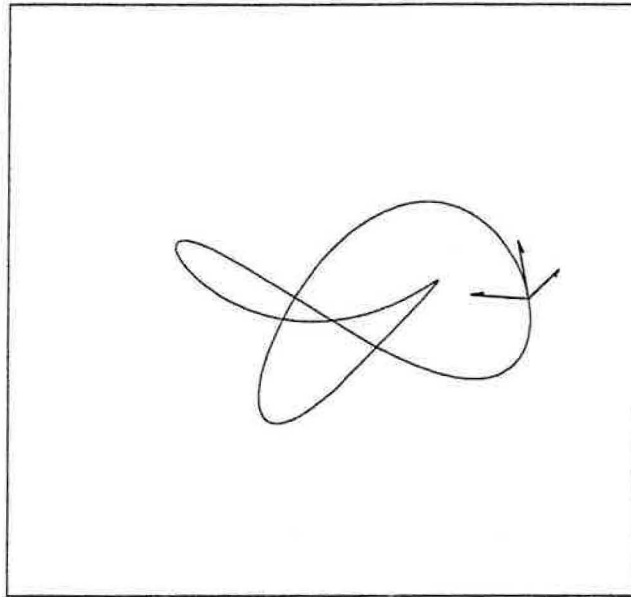

Please enter your 3D vector valued function below, use commas to separate the x y and z components of the function.

$$r(t) = (0.5 \cos[t] + \cos[2t], \sin[2t] - 0.5 \sin[t], 0.5 \sin[3t] + 0.5)$$

Click here \* when finished.

Now we compute the velocity and acceleration vectors from your function.

$$v(t) = (-0.5 \sin[t] - 2 \sin[2t], -0.5 \cos[t] + 2 \cos[2t], 1.5 \cos[3t])$$
$$a(t) = (-0.5 \cos[t] - 4 \cos[2t], 0.5 \sin[t] - 4 \sin[2t], -4.5 \sin[3t])$$

Enter the max and min values on the parameter t below. (Type 'p' to enter  $\pi$ ).

$$t_{\max} = 2\pi$$

$$t_{\min} = 0$$

The lengths of the vectors will be divided by "scale". Change this value to make the vectors appear longer or shorter.

$$\text{scale} = 2$$

Finally, you can enter the number of frames in the animation. Higher values make the animation smoother.

frames = 20

Click here \* to graph the function.

The graph is below. You can click and drag the graph to change the orientation. Click once on the graph to animate the velocity vector.

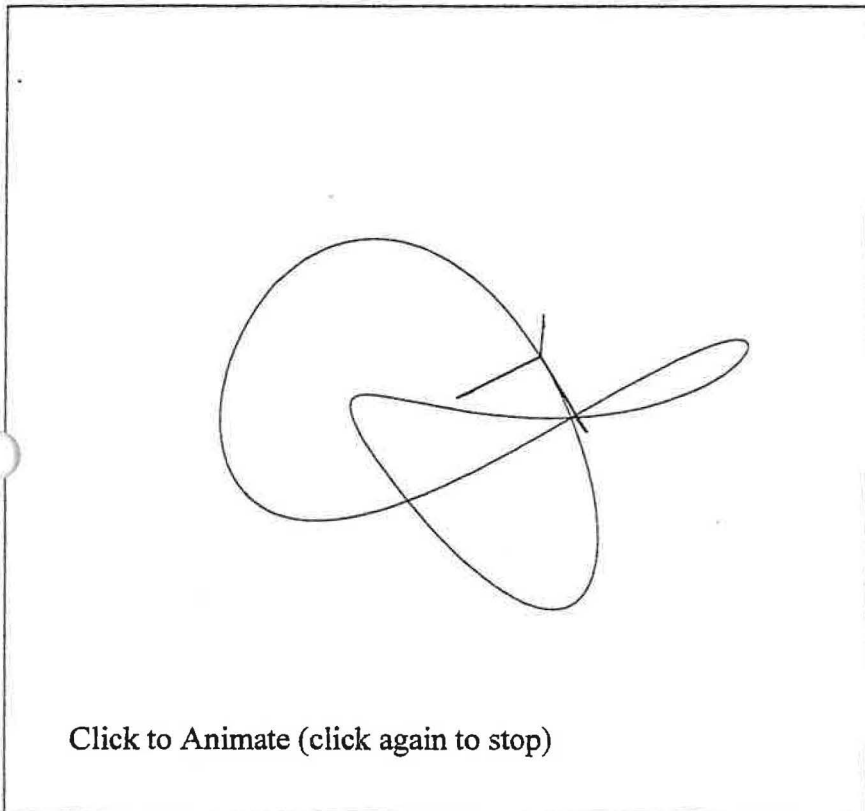

Animate this graph for  $t_z = t_{min} \dots t_{max}$  in steps of  $\frac{t_{max} - t_{min}}{\text{frames}}$  for a total of frames  at .

## Plotting 3D Surfaces over a Rectangular Domain & Surface Area

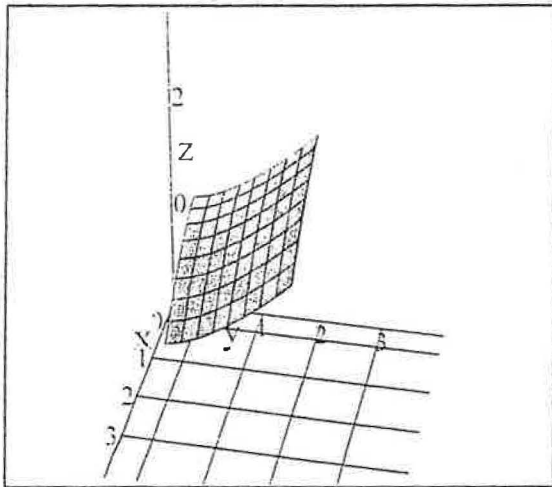

$f(x, y)$  is the surface to be plotted.

Please enter your surface  $f(x, y)$  below.

$f(x, y) = \frac{1 - x^{\frac{3}{2}} + y^{\frac{3}{2}}}{2}$

Please enter the left and right boundaries of the rectangular region.

$x_0 = 0$        $x_1 = 2$

Next, enter the limits on  $y$  below.

$y_0 = 0$        $y_1 = 2$

Click here \* when finished.

Next, we compute the surface area of the surface you've entered.

$$S = \int_{x_0}^{x_1} \left( \int_{y_0}^{y_1} \sqrt{\left[ \frac{\partial}{\partial x} f(x, y) \right]^2 + \left[ \frac{\partial}{\partial y} f(x, y) \right]^2 + 1} dy \right) dx$$

$$S = \int_0^2 \left( \int_0^2 \sqrt{\left[ \frac{\partial}{\partial x} \left\{ \frac{1}{2} (-x^{\frac{3}{2}} + y^{\frac{3}{2}} + 1) \right\} \right]^2 + \left[ \frac{\partial}{\partial y} \left\{ \frac{1}{2} (-x^{\frac{3}{2}} + y^{\frac{3}{2}} + 1) \right\} \right]^2 + 1} dy \right) dx$$

$$S = \int_0^2 \left( \int_0^2 \sqrt{\left[ \frac{3}{4} \sqrt{x} \right]^2 + \left[ \frac{3}{4} \sqrt{y} \right]^2 + 1} dy \right) dx$$

$$S = \int_0^2 \left( \int_0^2 \sqrt{\frac{9}{16}x + \frac{9}{16}y + 1} \, dy \right) dx$$
$$S = \frac{32}{1215} \cdot 13^{\frac{5}{2}} - \frac{8}{1215} \cdot 17^{\frac{5}{2}} \sqrt{2} + \frac{1024}{1215}$$
$$S = 5.7956$$

Finally we plot the surface. Please enter min and max values of x, y, and z. These values only define the viewing window. If your surface does not fit in the window, change the limits until it does.

xmin = -0.5      xmax = 4  
ymin = -0.5      ymax = 4  
zmin = -2        zmax = 4

Click here \* to view your surface.

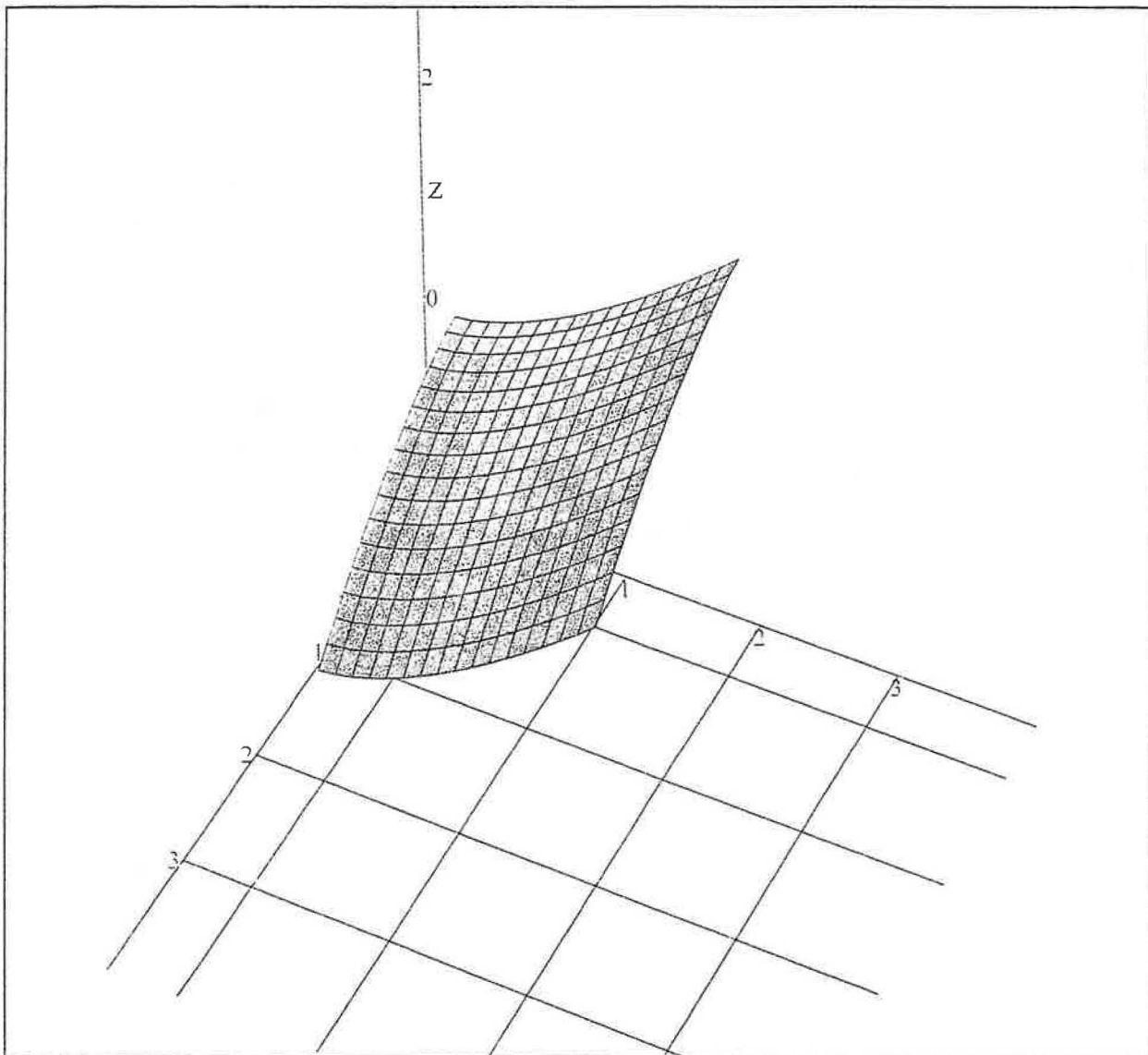

## Horizontally Simple Surfaces with Surface Area

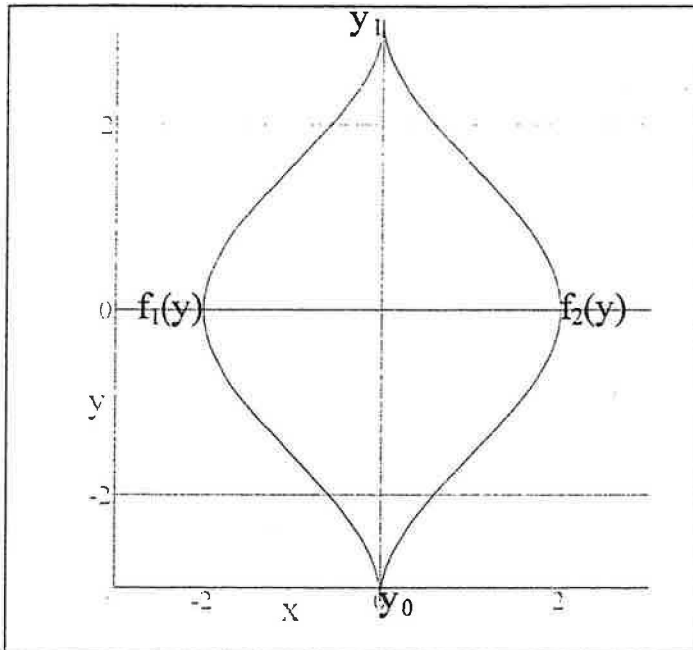

Please enter your surface  $f(x, y)$  below.

$$f(x, y) = e^{-x^2 - y^2}$$

Please enter the left and right boundaries of the horizontally simple region.

$f_1(x)$  is the left boundary of the region.  $f_2(x)$  is the right boundary.

$$f_1(y) = -\cos(y) - 1 \quad f_2(y) = \cos(y) + 1$$

Next, enter the limits on  $y$  below.

$$y_0 = -\pi \quad y_1 = \pi$$

Click here \* when finished.

Here we compute the surface area,  $S$ , of the surface you've defined.

$$S = \int_{y_0}^{y_1} \left( \int_{f_1[y]}^{f_2[y]} \sqrt{\left[ \frac{\partial}{\partial x} f(x, y) \right]^2 + \left[ \frac{\partial}{\partial y} f(x, y) \right]^2 + 1} dx \right) dy$$

$$S = \int_{-\pi}^{\pi} \left( \int_{-\cos[y]-1}^{\cos[y]+1} \sqrt{\left[ \frac{\partial}{\partial x} e^{-x^2 - y^2} \right]^2 + \left[ \frac{\partial}{\partial y} e^{-x^2 - y^2} \right]^2 + 1} dx \right) dy$$

$$S = \int_{-\pi}^{\pi} \left( \int_{-\cos[y]-1}^{\cos[y]+1} \sqrt{4e^{2[-x^2 - y^2]} x^2 + 4e^{2[-x^2 - y^2]} y^2 + 1} dx \right) dy$$

$$S = 13.974$$



Finally we plot the surface and the vector field. Please enter min and max values of  $x$ ,  $y$ , and  $z$ . These values define the viewing window. If your surface does not fit in the window, change the limits until it does.

$$x_{\min} = -3 \quad x_{\max} = 3$$

$$y_{\min} = -3 \quad y_{\max} = 3$$

$$z_{\min} = -1 \quad z_{\max} = 1$$

Click here \* to see your graph.

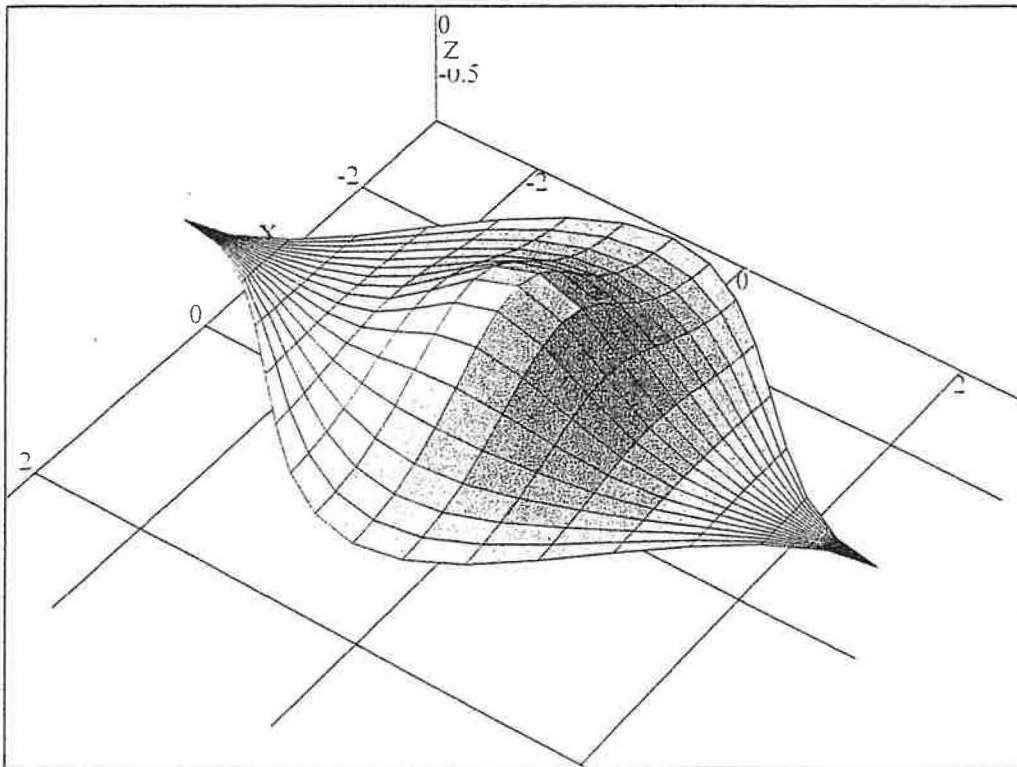

Copyright July 2000 by Scott Guth  
Mt. San Antonio College

## Vertically Simple Surfaces with Surface Area

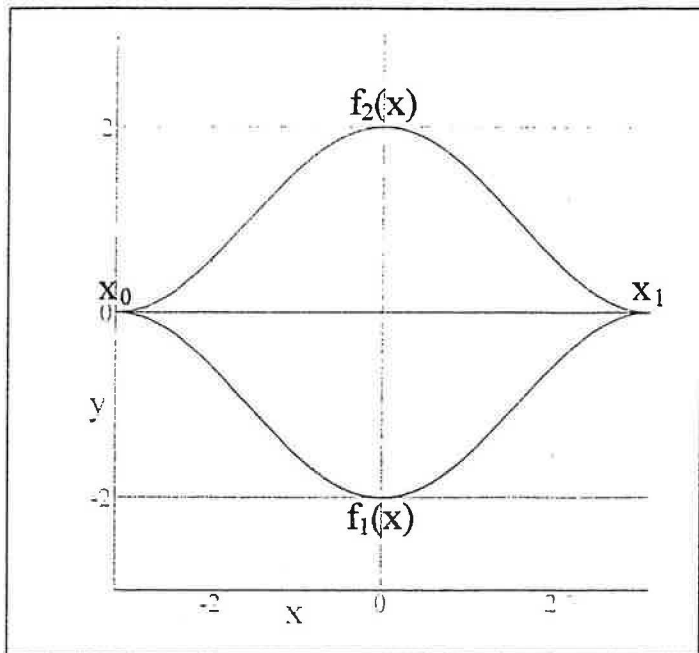

Please enter your surface  $f(x, y)$  below.

$$f(x, y) = e^{-x^2 - y^2}$$

Please enter the bottom and top boundaries of the vertically simple region.

$f_1(x)$  is the bottom boundary of the region.  $f_2(x)$  is the top boundary.

$$f_1(x) = -\cos(x) - 1 \quad f_2(x) = \cos(x) + 1$$

Next, enter the limits on  $x$  below.

$$x_0 = -\pi \quad x_1 = \pi$$

Click here \* to continue.

Next, we will set up the integral for surface area,  $S$ .

$$S = \int_{x_0}^{x_1} \left( \int_{f_1[x]}^{f_2[x]} \sqrt{\left[ \frac{\partial}{\partial x} f\{x, y\} \right]^2 + \left[ \frac{\partial}{\partial y} f\{x, y\} \right]^2 + 1} dy \right) dx$$

$$S = \int_{-\pi}^{\pi} \left( \int_{-\cos[x]-1}^{\cos[x]+1} \sqrt{\left[ \frac{\partial}{\partial x} e^{-x^2-y^2} \right]^2 + \left[ \frac{\partial}{\partial y} e^{-x^2-y^2} \right]^2 + 1} dy \right) dx$$

$$S = \int_{-\pi}^{\pi} \left( \int_{-\cos[x]-1}^{\cos[x]+1} \sqrt{4e^{2[-x^2-y^2]}x^2 + 4e^{2[-x^2-y^2]}y^2 + 1} dy \right) dx$$

$$S = 13.974$$

Finally we plot the surface and the vector field. Please enter min and max values of  $x$ ,  $y$ , and  $z$ . These values define the viewing window. If your surface does not fit in the window, change the limits until it does.

$$x_{\min} = -\pi \quad x_{\max} = \pi$$

$$y_{\min} = -3 \quad y_{\max} = 3$$

$$z_{\min} = -1 \quad z_{\max} = 1$$

Click here \* to view your graph.

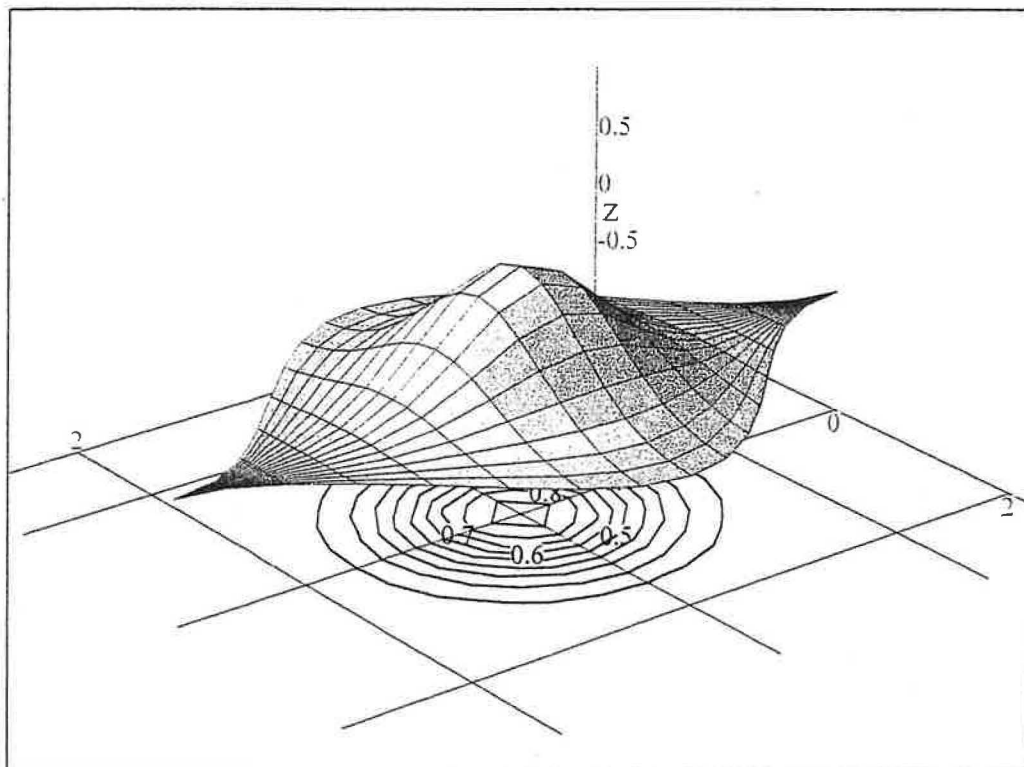

Copyright July 2000 by Scott Guth  
Mt. San Antonio College

## 3D Parametric Surfaces with Vector Fields with Surface Area

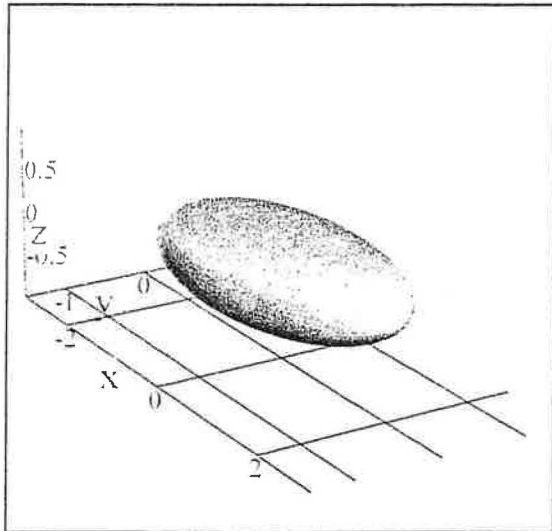

Please enter your parametric surface below as a function of  $u$  and  $v$ . Separate the  $x$ ,  $y$ , and  $z$  components by commas.

$r(u, v) = \left( 2 \sin[v] \cos[u], \sin[v] \sin[u], \frac{\cos[v]}{2} \right)$

Click here \* when done.

Now we need limits on the parameters  $u$  and  $v$ .

$$\begin{aligned} v_{\min} &= 0 & v_{\max} &= \pi \\ u_{\min} &= 0 & u_{\max} &= 2\pi \end{aligned}$$

Below we compute the area of your surface.

$$S = \int_{v_{\min}}^{v_{\max}} \left( \int_{u_{\min}}^{u_{\max}} \left| \frac{\partial}{\partial u} r[u, v] \times \frac{\partial}{\partial v} r[u, v] \right| du \right) dv$$

$$S = 15.8691620027263$$

Finally we need limits on  $x$ ,  $y$ , and  $z$ . These are used only to define the size of the window. If your surface doesn't fit in the plot window, widen the range on these limits.

$$\begin{aligned} x_{\min} &= -3 & x_{\max} &= 3 \\ y_{\min} &= -1.5 & y_{\max} &= 1.5 \\ z_{\min} &= -1 & z_{\max} &= 1 \end{aligned}$$

Click here \* to see your graph.

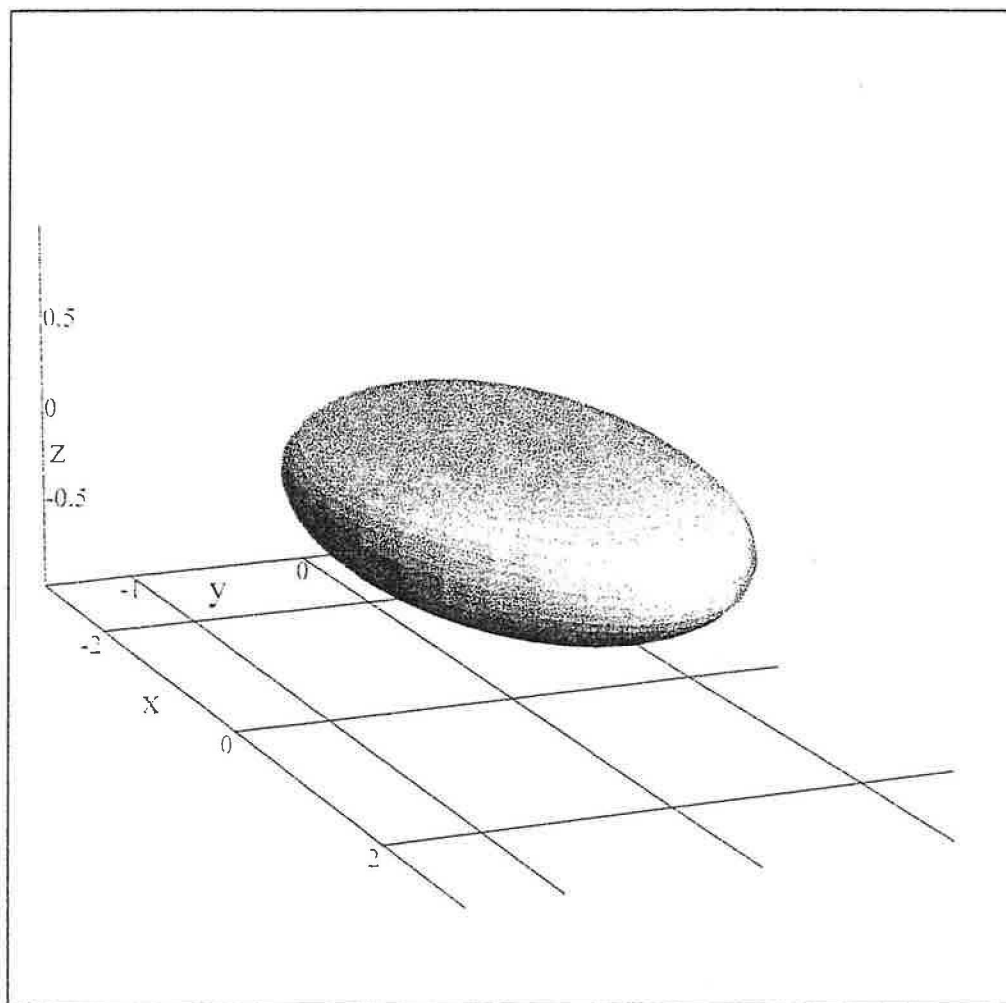

Copyright July 2000 by Scott Guth  
Mt. San Antonio College

## Implicit Surface Plotter

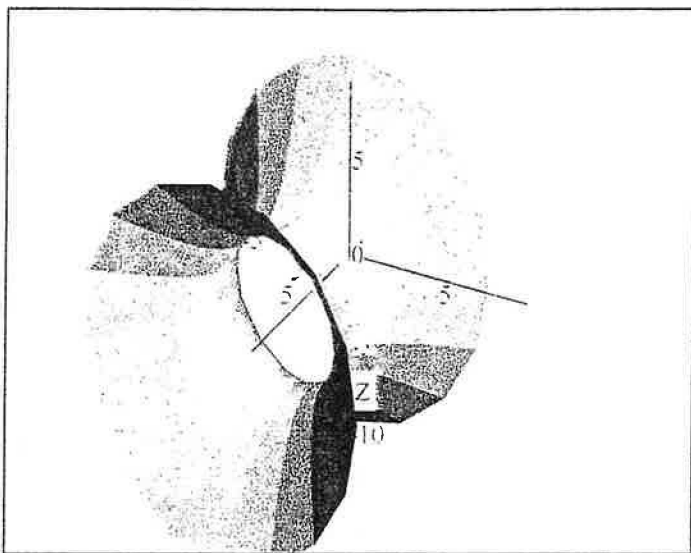

This utility plots surfaces defined implicitly. The equation to be plotted must be quadratic or linear in  $x$ ,  $y$ , and  $z$ . This means that the equation must be expressible in the form:  $ax^2 + bx + cy^2 + fy + gz^2 + hz + k = 0$ . (The equation must be expressible in this form, but you don't need to actually put it into this form... Livemath will take care of that for you).

We will let  $F(x,y,z)$  be the right hand side of the equation to be plotted. Please enter  $F(x,y,z)$  below:

$$F(x, y, z) = -2x^2 + 6x + 2y^2 + 10y + 1z^2 + 6z - 2$$

Click here \* when finished.

Here we give a parameterization of this surface:

$$r(u, v) = \left( \frac{1}{2}\sqrt{38} \sinh[v] + \frac{3}{2}, \frac{1}{2}\sqrt{38} \cos[u] \cosh[v] - \frac{5}{2}, \sqrt{19} \cosh[v] \sin[u] - 3 \right)$$

And the surface is plotted below.

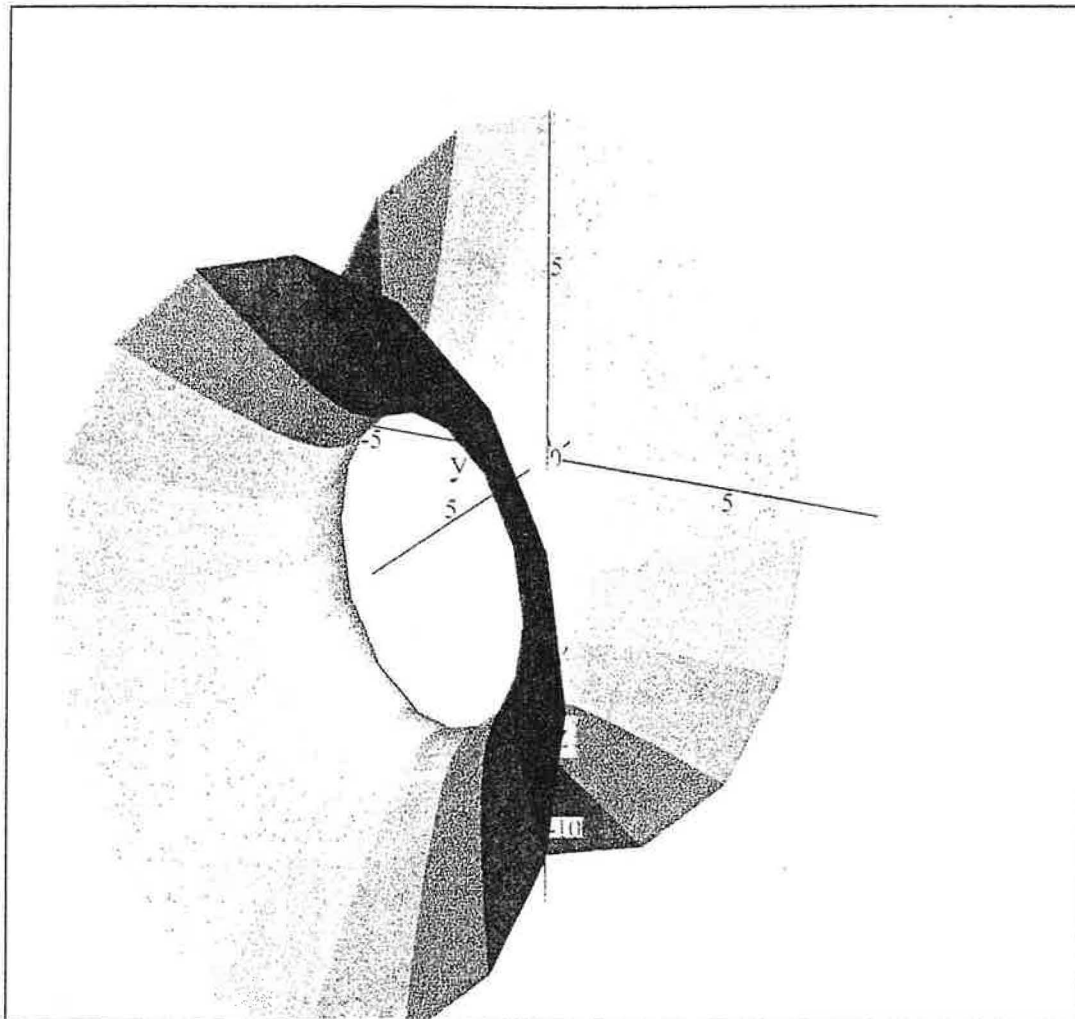

Copyright July 2000 by Scott Guth  
Mt. San Antonio College

## Surfaces over Rectangular Domains with Tangent Plane

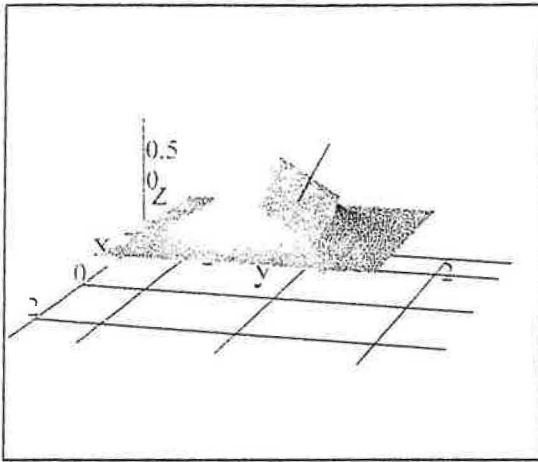

Please enter your surface  $f(x, y)$  below.

$$f(x, y) = e^{-x^2 - y^2}$$

Enter the limits on  $x$  below

$$x_0 = -2 \quad x_1 = 2$$

Next, enter the limits on  $y$  below.

$$y_0 = -2 \quad y_1 = 2$$

Click here \* when finished.

Now we will compute the tangent plane and normal line. Please enter the coordinates  $(h, k)$  for the point of tangency.

$$h = 0.5 \quad k = 0.5$$

Click here \* when done.

The point  $P$  will be the point where the tangent plane touches the surface.

$$P = \left( 0.5, 0.5, \frac{1}{e^{0.5}} \right)$$

And the vector,  $N$ , which is normal to the surface at  $P$  is below.

$$N = \left( -\frac{\partial}{\partial x} f[x, y], -\frac{\partial}{\partial y} f[x, y], 1 \right)$$

$$N = \left( 2e^{-x^2 - y^2} x, 2e^{-x^2 - y^2} y, 1 \right)$$



$$N = \left( \frac{1}{e^{0.5}}, \frac{1}{e^{0.5}}, 1 \right)$$

$$N = (0.60653, 0.60653, 1)$$

Here we find the equation of the tangent plane.

$$N \cdot (x - h, y - k, z - z_0) = 0$$

$$\left( \frac{1}{e^{0.5}}, \frac{1}{e^{0.5}}, 1 \right) \cdot \left( x - 0.5, y - 0.5, z - \frac{1}{e^{0.5}} \right) = 0$$

$$\frac{x - 0.5}{e^{0.5}} + \frac{y - 0.5}{e^{0.5}} + z - \frac{1}{e^{0.5}} = 0$$

$$z = -\frac{x - 0.5}{e^{0.5}} - \frac{y - 0.5}{e^{0.5}} + \frac{1}{e^{0.5}}$$

Finally we plot the surface and the vector field. Please enter min and max values of x, y, and z. These values define the viewing window. If your surface does not fit in the window, change the limits until it does.

$$\begin{array}{ll} \text{xmin} = -3 & \text{xmax} = 3 \\ \text{ymin} = -3 & \text{ymax} = 3 \\ \text{zmin} = -1 & \text{zmax} = 1 \end{array}$$

Click here \* to see your graph.

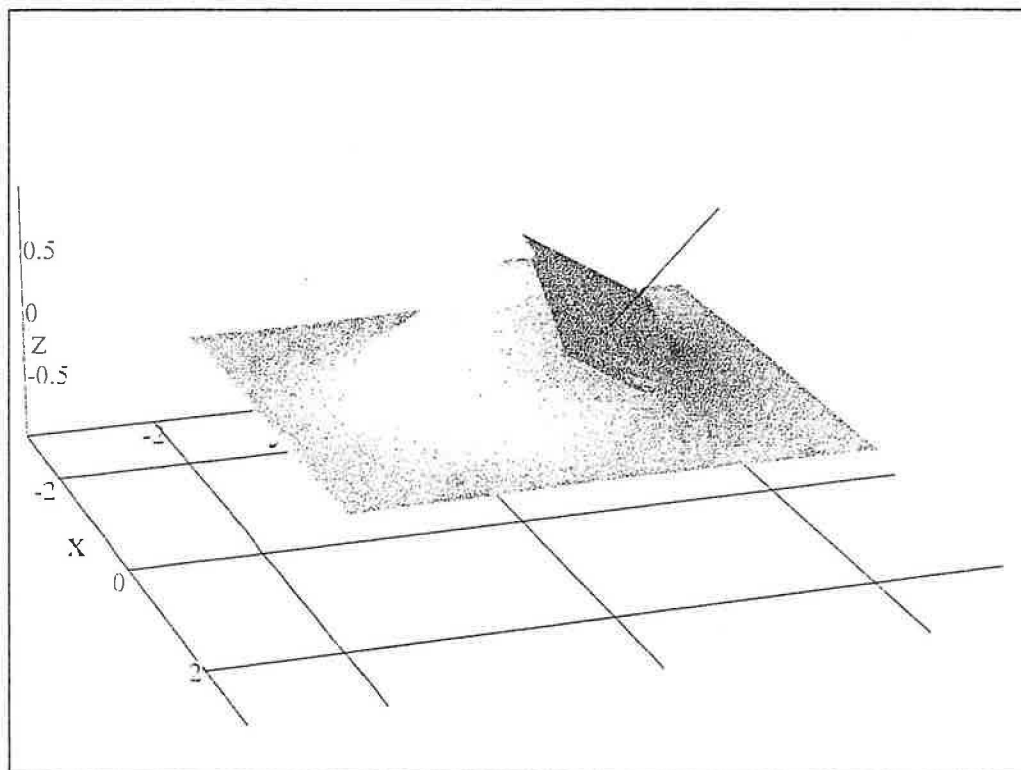

## Horizontally Simple Surfaces with Tangent Plane

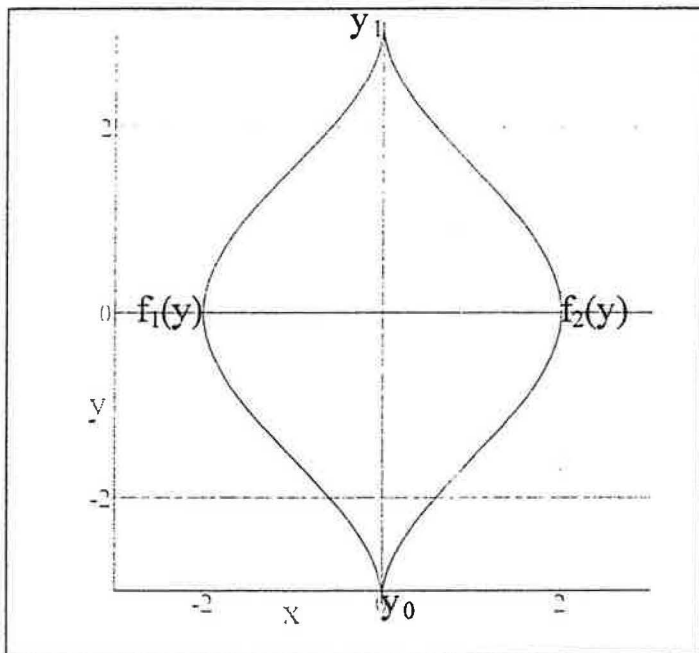

Please enter your surface  $f(x, y)$  below.

$$f(x, y) = e^{-x^2 - y^2}$$

Please enter the left and right boundaries of the horizontally simple region.

$f_1(x)$  is the left boundary of the region.  $f_2(x)$  is the right boundary.

$$f_1(y) = -\cos(y) - 1 \quad f_2(y) = \cos(y) + 1$$

Next, enter the limits on  $y$  below.

$$y_0 = -\pi \quad y_1 = \pi$$

Click here \* when finished.

Now we will compute the tangent plane and normal line. Please enter the coordinates  $(h, k)$  for the point of tangency.

$$h = 0.5 \quad k = 0.5$$

Click here \* when done.

The point  $P$  will be the point where the tangent plane touches the surface.

$$P = \left( 0.5, 0.5, \frac{1}{e^{0.5}} \right)$$

And the vector,  $N$ , which is normal to the surface at  $P$  is below.

$$\begin{aligned} N &= \left( -\frac{\partial}{\partial x} f[x, y], -\frac{\partial}{\partial y} f[x, y], 1 \right) \\ N &= \left( 2e^{-x^2-y^2}x, 2e^{-x^2-y^2}y, 1 \right) \\ N &= \left( \frac{1}{e^{0.5}}, \frac{1}{e^{0.5}}, 1 \right) \\ N &= (0.60653, 0.60653, 1) \end{aligned}$$

Here we find the equation of the tangent plane.

$$\begin{aligned} N \cdot (x - h, y - k, z - z_0) &= 0 \\ \left( \frac{1}{e^{0.5}}, \frac{1}{e^{0.5}}, 1 \right) \cdot \left( x - 0.5, y - 0.5, z - \frac{1}{e^{0.5}} \right) &= 0 \\ \frac{x - 0.5}{e^{0.5}} + \frac{y - 0.5}{e^{0.5}} + z - \frac{1}{e^{0.5}} &= 0 \\ z &= -\frac{x - 0.5}{e^{0.5}} - \frac{y - 0.5}{e^{0.5}} + \frac{1}{e^{0.5}} \end{aligned}$$

Finally we plot the surface and the vector field. Please enter min and max values of  $x$ ,  $y$ , and  $z$ . These values define the viewing window. If your surface does not fit in the window, change the limits until it does.

$$\begin{array}{ll} x_{\min} = -3 & x_{\max} = 3 \\ y_{\min} = -3 & y_{\max} = 3 \\ z_{\min} = -1 & z_{\max} = 1 \end{array}$$

Click here \* to see your graph.

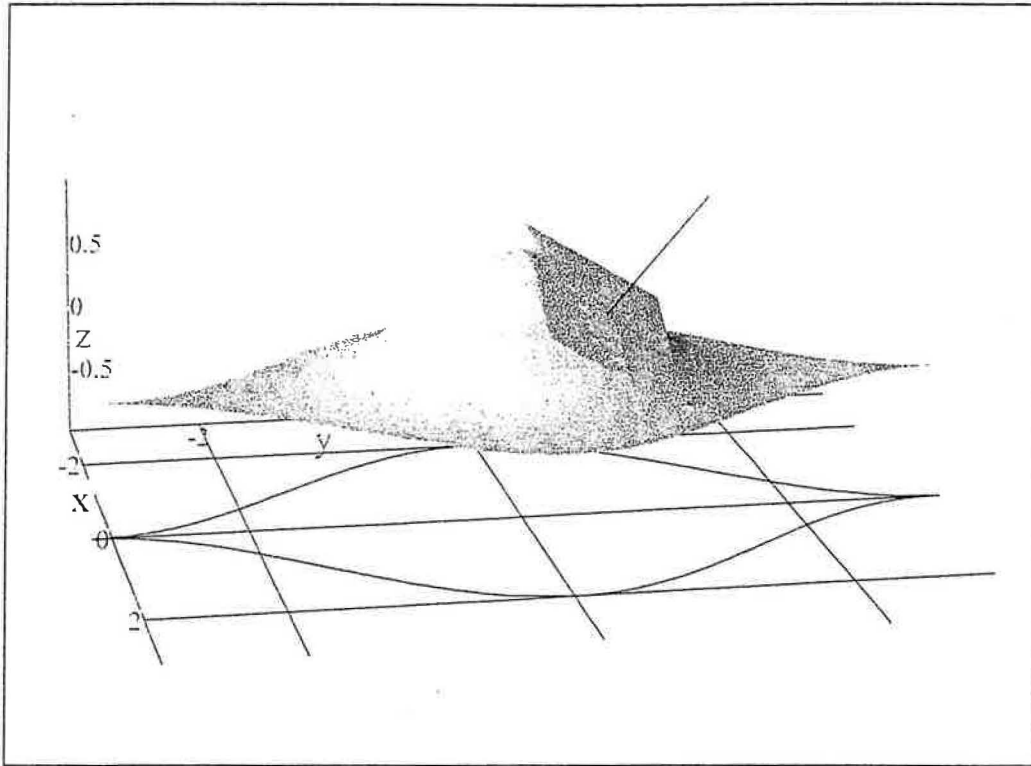

Copyright July 2000 by Scott Guth  
Mt. San Antonio College

## Vertically Simple Surfaces with Tangent Plane

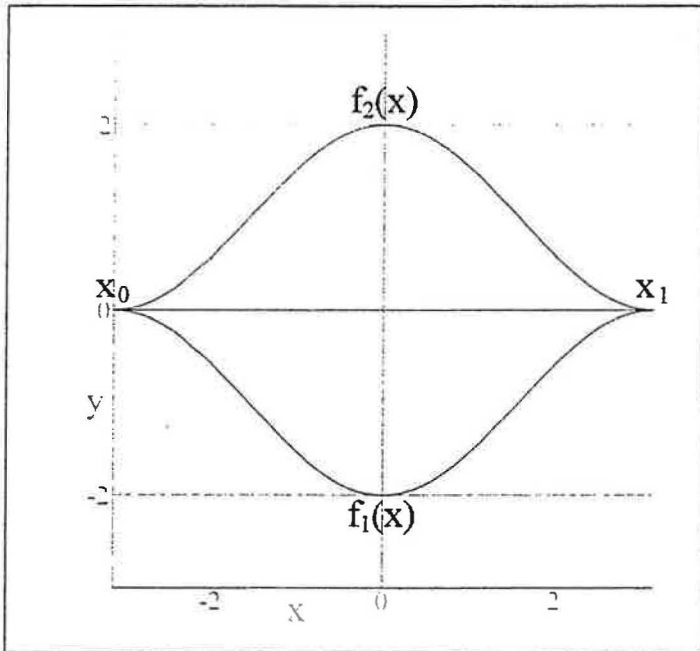

Please enter your surface  $f(x, y)$  below.

$$f(x, y) = e^{-x^2 - y^2}$$

Please enter the bottom and top boundaries of the vertically simple region.

$f_1(x)$  is the bottom boundary of the region.  $f_2(x)$  is the top boundary.

$$f_1(x) = -\cos(x) - 1 \quad f_2(x) = \cos(x) + 1$$

Next, enter the limits on  $x$  below.

$$x_0 = -\pi \quad x_1 = \pi$$

Click here \* to continue.

Now we will compute the tangent plane and normal line. Please enter the coordinates  $(h, k)$  for the point of tangency.

$$h = 0.5 \quad k = 0.5$$

The point  $P$  will be the point where the tangent plane touches the surface.

$$P = \left( 0.5, 0.5, \frac{1}{e^{0.5}} \right)$$

Click here \* when done.

And the vector,  $N$ , which is normal to the surface at  $P$  is below.

$$N = \left( -\frac{\partial}{\partial x} f[x, y], -\frac{\partial}{\partial y} f[x, y], 1 \right)$$

$$N = \left( 2e^{-x^2-y^2}x, 2e^{-x^2-y^2}y, 1 \right)$$

$$N = \left( \frac{1}{e^{0.5}}, \frac{1}{e^{0.5}}, 1 \right)$$

And next we find the equation of the tangent plane.

$$N \cdot (x - h, y - k, z - z_0) = 0$$

$$\left( \frac{1}{e^{0.5}}, \frac{1}{e^{0.5}}, 1 \right) \cdot \left( x - 0.5, y - 0.5, z - \frac{1}{e^{0.5}} \right) = 0$$

$$\frac{x - 0.5}{e^{0.5}} + \frac{y - 0.5}{e^{0.5}} + z - \frac{1}{e^{0.5}} = 0$$

$$z = -\frac{x - 0.5}{e^{0.5}} - \frac{y - 0.5}{e^{0.5}} + \frac{1}{e^{0.5}}$$

Finally we plot the surface and the vector field. Please enter min and max values of  $x$ ,  $y$ , and  $z$ . These values define the viewing window. If your surface does not fit in the window, change the limits until it does.

$$\begin{array}{ll} x_{\min} = -\pi & x_{\max} = \pi \\ y_{\min} = -3 & y_{\max} = 3 \\ z_{\min} = -1 & z_{\max} = 1 \end{array}$$

Click here \* to view your graph.

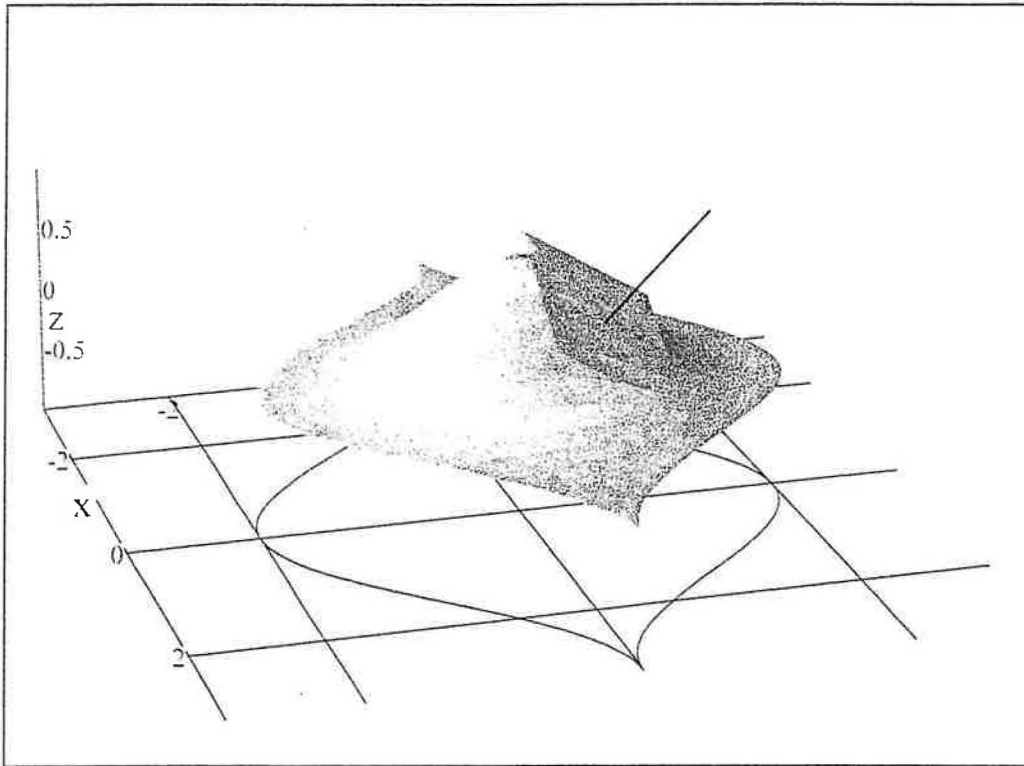

Copyright July 2000 by Scott Guth  
Mt. San Antonio College

## Parameterized Surfaces: Tangent Plane & Normal Line

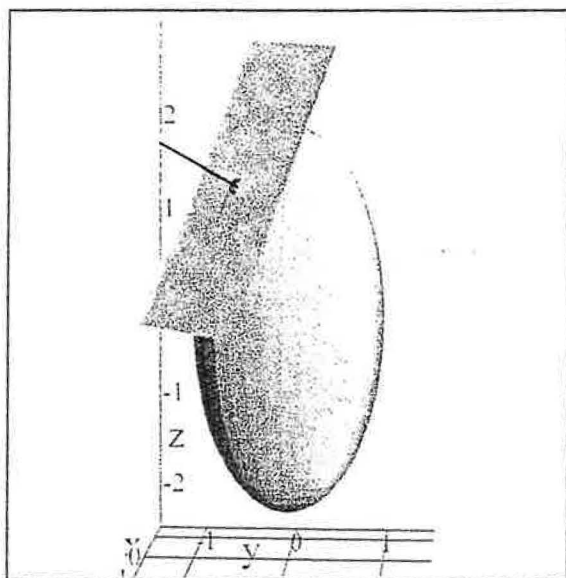

Please enter your parametric surface below as a function of  $u$  and  $v$ . Separate the  $x$ ,  $y$ , and  $z$  components by commas.

$$r(u, v) = (\sin[v]\cos[u], \sin[v]\sin[u], 2\cos[v])$$

Click here \* when done.

Now we need limits on the parameters  $u$  and  $v$ .

$$\begin{aligned} v_{\min} &= 0 & v_{\max} &= \pi \\ u_{\min} &= 0 & u_{\max} &= 2\pi \end{aligned}$$

Next we need limit on  $x$ ,  $y$ , and  $z$ . These are used only to define the size of the window. (If the surface doesn't fit the window, adjust these values).

$$\begin{aligned} x_{\min} &= -1.5 & x_{\max} &= 1.5 \\ y_{\min} &= -1.5 & y_{\max} &= 1.5 \\ z_{\min} &= -2.5 & z_{\max} &= 3 \end{aligned}$$

Now we will compute the tangent plane and normal line. Please enter specific values  $u_0$  and  $v_0$  for the parameters  $u$  and  $v$  below.

$$u_0 = \frac{7\pi}{4} \quad v_0 = \frac{\pi}{4}$$

Click here \* when done.



The point  $P = r(u_0, v_0)$  has  $(x,y,z)$  coordinates given below.

$$P = (0.5, -0.5, 1.4142135623731)$$

And the vector,  $N$ , which is normal to the surface at  $P$  is below.

$$N = \left(-\frac{1}{2}\sqrt{2}, \frac{1}{2}\sqrt{2}, -\frac{1}{2}\right)$$

And here is the graph of your surface.

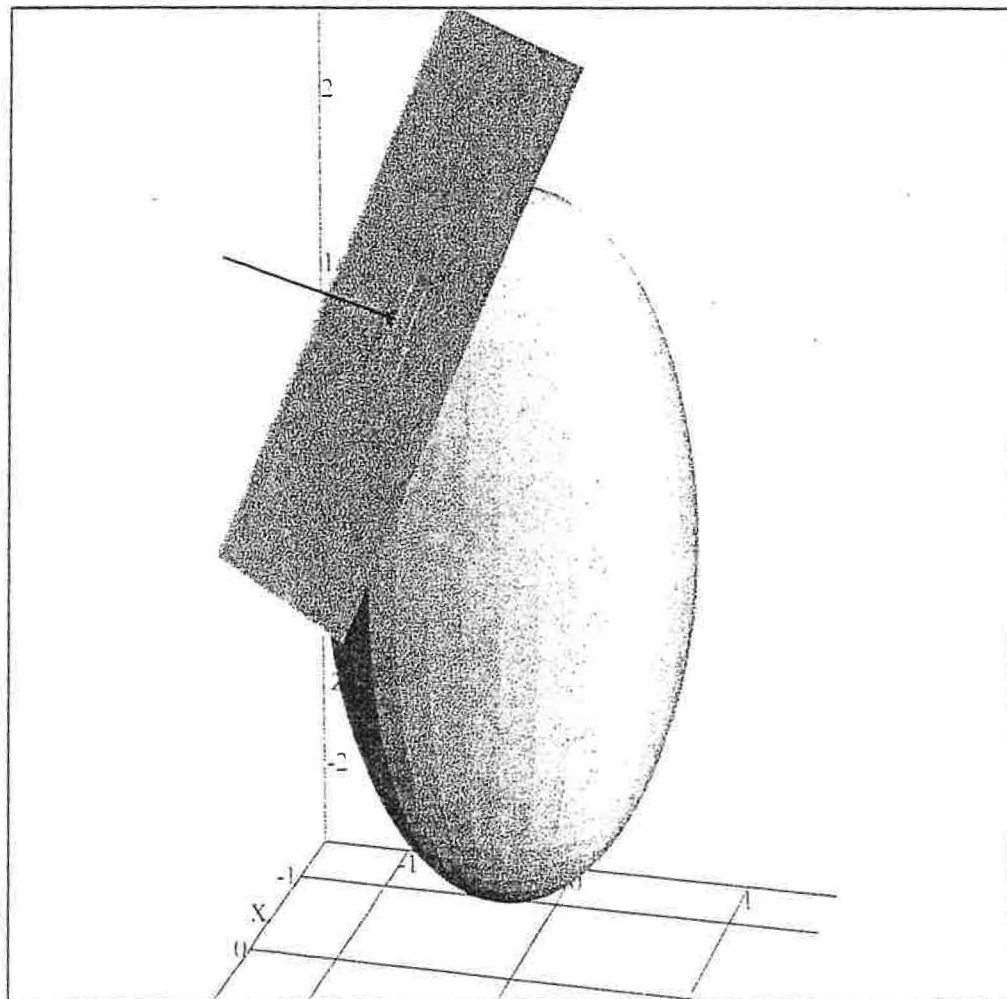

Copyright July 2000 by Scott Guth  
Mt. San Antonio College

## Plotting 3D Surfaces over a Rectangular Domain Gradient vs. Level Curves

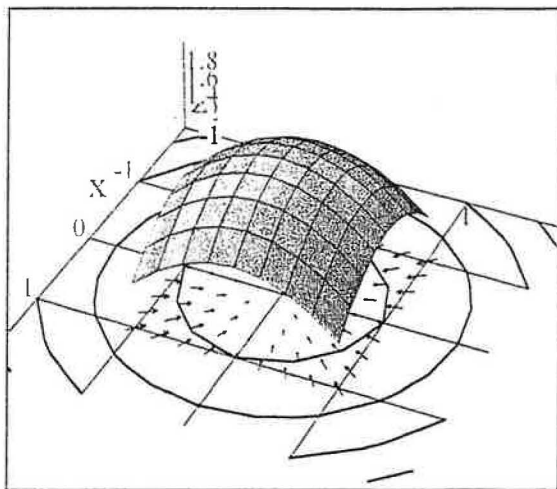

Please enter your surface  $f(x, y)$  below.

$$f(x, y) = \frac{5 - x^2 - y^2}{2}$$

Please enter the left and right boundaries of the rectangular region.

$$x_0 = -1 \quad x_1 = 1$$

Next, enter the limits on  $y$  below.

$$y_0 = -1 \quad y_1 = 1$$

Click here \* when finished.

Next, we compute the 2D gradient of  $f(x, y)$ .

$$\begin{aligned} \text{gradient} &= \text{Grad}(f[x, y]) \\ \text{gradient} &= \text{Grad}\left(\frac{1}{2}[-x^2 - y^2 + 5]\right) \\ \text{gradient} &= (-x, -y) \end{aligned}$$

Finally we plot the surface. Please enter min and max values of  $x$ ,  $y$ , and  $z$ . These values only define the viewing window. If your surface does not fit in the window, change the limits until it does.

$$\begin{aligned} x_{\min} &= -2 & x_{\max} &= 2 \\ y_{\min} &= -2 & y_{\max} &= 2 \\ z_{\min} &= 1 & z_{\max} &= 2 \end{aligned}$$

Click here \* to view your surface.

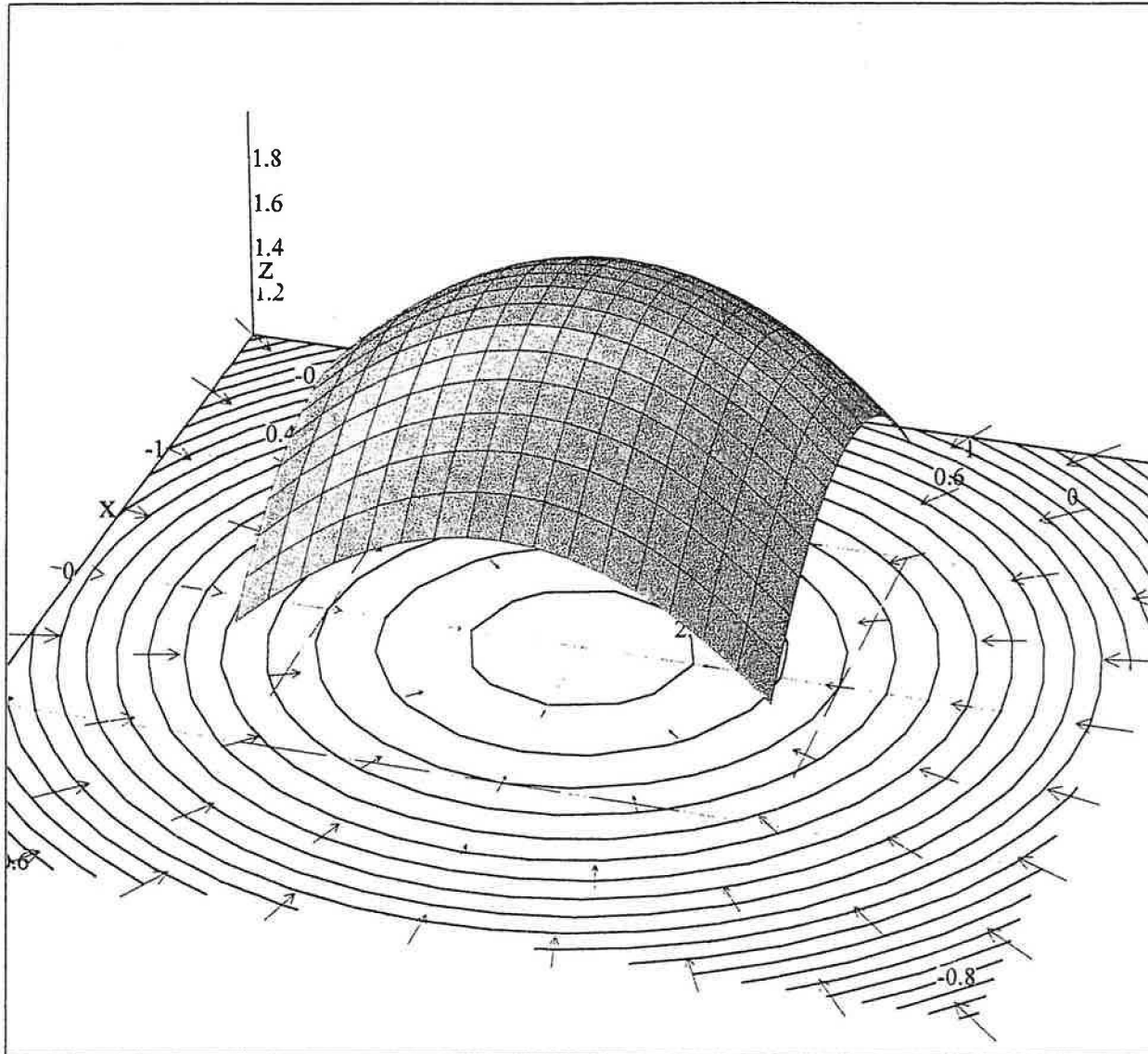

Copyright July 2000 by Scott Guth  
Mt. San Antonio College

## Horizontally Simple Surfaces Gradient vs. Level Curves

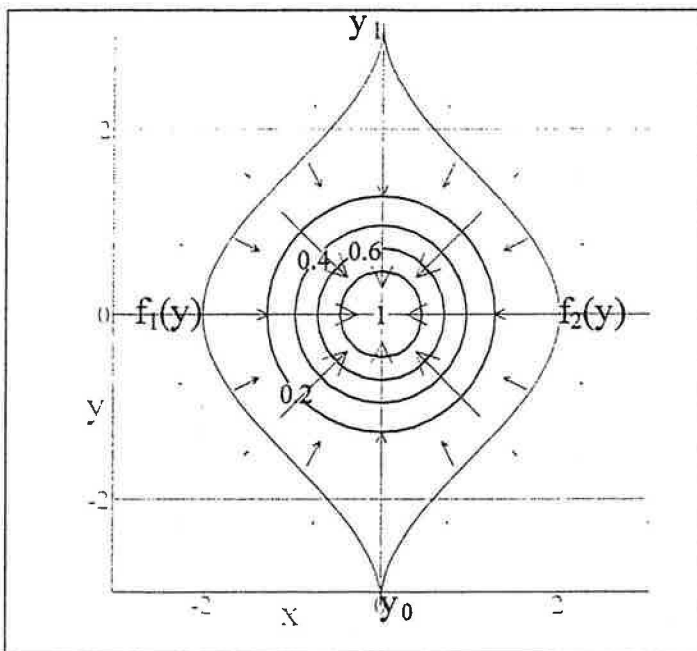

Please enter your surface  $f(x, y)$  below.

$f(x, y) = e^{-x^2 - y^2}$

Please enter the left and right boundaries of the horizontally simple region.

$f_1(x)$  is the left boundary of the region.  $f_2(x)$  is the right boundary.

$f_1(y) = -\cos(y) - 1$        $f_2(y) = \cos(y) + 1$

Next, enter the limits on  $y$  below.

$y_0 = -\pi$        $y_1 = \pi$

Click here \* when finished.

Next, we compute the 2D gradient of  $f(x, y)$ .

gradient = Grad( $f[x, y]$ )

gradient = Grad( $e^{-x^2 - y^2}$ )      Substitute

gradient =  $(-2e^{-x^2 - y^2}x, -2e^{-x^2 - y^2}y)$       Substitute

Finally we plot the surface and the vector field. Please enter min and max values of  $x$ ,  $y$ , and  $z$ . These values define the viewing window. If your surface does not fit in the window, change the limits until it does.

$x_{\min} = -3$        $x_{\max} = 3$   
 $y_{\min} = -3$        $y_{\max} = 3$   
 $z_{\min} = -1$        $z_{\max} = 1$

Click here \* to see your graph.

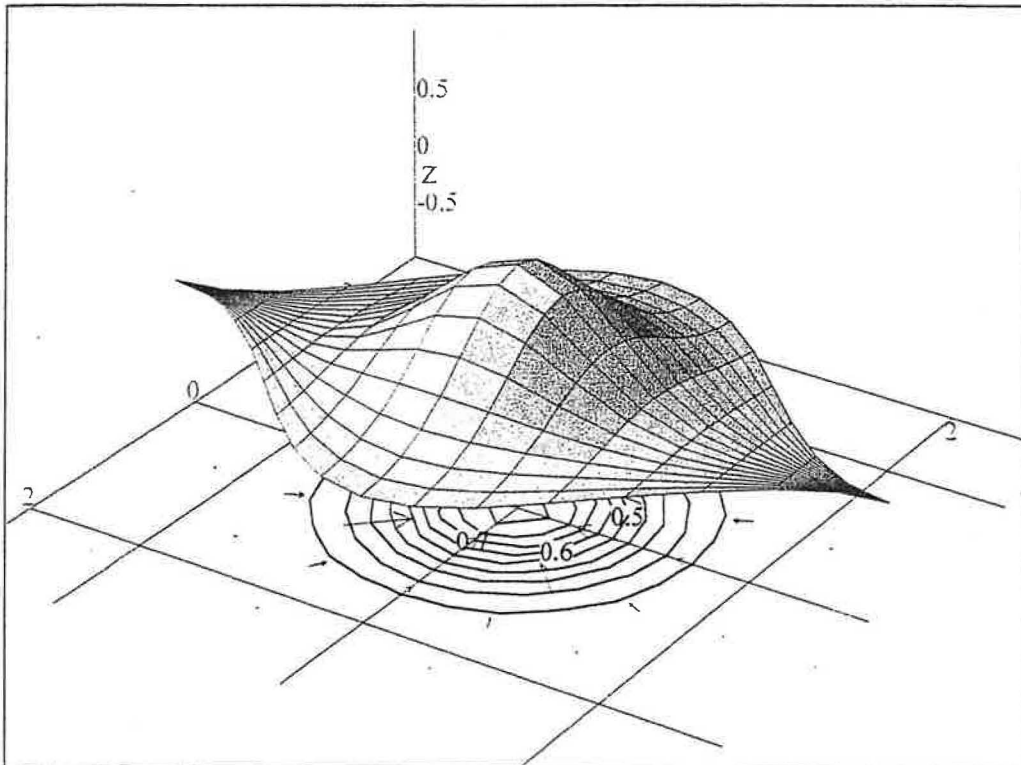

Copyright July 2000 by Scott Guth  
Mt. San Antonio College

## Vertically Simple Surfaces with Surface Area Gradient vs. Level Curves

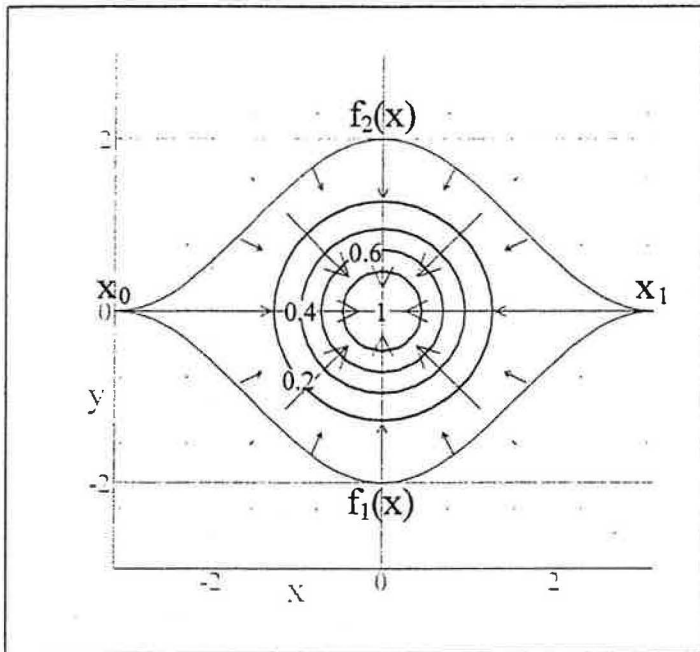

Please enter your surface  $f(x, y)$  below.

$f(x, y) = e^{-x^2 - y^2}$

Please enter the bottom and top boundaries of the vertically simple region.

$f_1(x)$  is the bottom boundary of the region.  $f_2(x)$  is the top boundary.

$$f_1(x) = -\cos(x) - 1 \quad f_2(x) = \cos(x) + 1$$

Next, enter the limits on  $x$  below.

$$x_0 = -\pi \quad x_1 = \pi$$

Click here \* to continue.

Next, we compute the 2D gradient of  $f(x, y)$ .

$$\text{gradient} = \text{Grad}(f[x, y])$$

$$\text{gradient} = \text{Grad}(e^{-x^2 - y^2})$$

$$\text{gradient} = (-2e^{-x^2 - y^2}x, -2e^{-x^2 - y^2}y)$$

Finally we plot the surface and the vector field. Please enter min and max values of  $x$ ,  $y$ , and  $z$ . These values define the viewing window. If your surface does not fit in the window, change the limits until it does.

$$\begin{aligned}x_{\min} &= -\pi & x_{\max} &= \pi \\y_{\min} &= -3 & y_{\max} &= 3 \\z_{\min} &= -1 & z_{\max} &= 1\end{aligned}$$

Click here \* to view your graph.

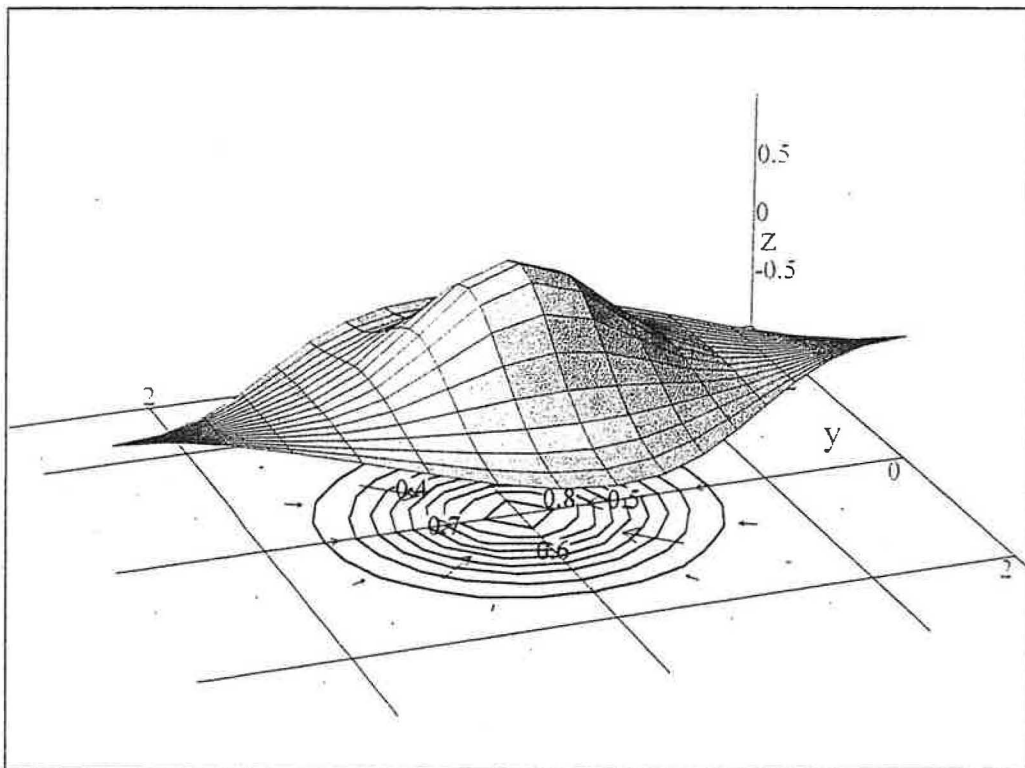

Copyright July 2000 by Scott Guth  
Mt. San Antonio College

Next we evaluate the surface integral for flux:

$$\text{Flux} = \int F \cdot N \, dS$$

$$\text{Flux} = \int_{-\pi}^{\pi} \left( \int_{-\cos[y]-1}^{\cos[y]+1} [F\{x, y, f(x, y)\} \cdot \{x, y, 1\}] \, dx \right) dy$$

$$\text{Flux} = \int_{-\pi}^{\pi} \left( \int_{-\cos[y]-1}^{\cos[y]+1} [F\{x, y, \frac{1}{2}(-x^2 - y^2 + 1)\} \cdot \{x, y, 1\}] \, dx \right) dy$$

$$\text{Flux} = \int_{-\pi}^{\pi} \left( \int_{-\cos[y]-1}^{\cos[y]+1} [\{-y, x, \frac{1}{2}(\frac{1}{2}[-x^2 - y^2 + 1])\} \cdot \{x, y, 1\}] \, dx \right) dy$$

$$\text{Flux} = \int_{-\pi}^{\pi} \left( \int_{-\cos[y]-1}^{\cos[y]+1} [-\frac{1}{4}x^2 - \frac{1}{4}y^2 + \frac{1}{4}] \, dx \right) dy$$

$$\text{Flux} = -\frac{1}{3}\pi^3 + \frac{13}{6}\pi$$

$$\text{Flux} = -3.5286$$

Finally we plot the surface and the vector field. Please enter min and max values of x, y, and z. These values define the viewing window. If your surface does not fit in the window, change the limits until it does.

$$x_{\min} = -4 \quad x_{\max} = 4$$

$$y_{\min} = -4 \quad y_{\max} = 4$$

$$z_{\min} = -5 \quad z_{\max} = 1$$



## Horizontally Simple Surfaces with Vector Fields and Flux

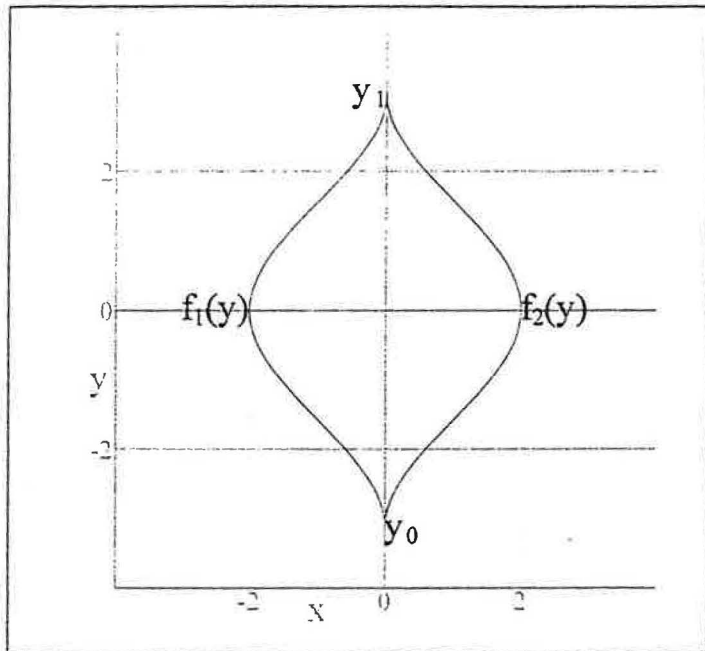

Please enter your surface  $f(x, y)$  below.

$$f(x, y) = \frac{1 - x^2 - y^2}{2}$$

Please enter the left and right boundaries of the horizontally simple region.

$f_1(x)$  is the left boundary of the region.  $f_2(x)$  is the right boundary.

$$f_1(y) = -\cos(y) - 1 \quad f_2(y) = \cos(y) + 1$$

Next, enter the limits on  $y$  below.

$$y_0 = -\pi \quad y_1 = \pi$$

Enter your vector field below. Separate the  $x$ ,  $y$ , and  $z$  components by commas.

$$F(x, y, z) = \left( -y, x, \frac{z}{2} \right)$$

Click here \* when finished.

We now proceed to compute the flux of  $F$  through  $z = f(x, y)$ . First, we compute  $N \, dS$ , the unit normal times the differential of surface area.

$$N \, dS = \left( -\frac{\partial}{\partial x} f[x, y], -\frac{\partial}{\partial y} f[x, y], 1 \right)$$

$$N \, dS = (x, y, 1)$$

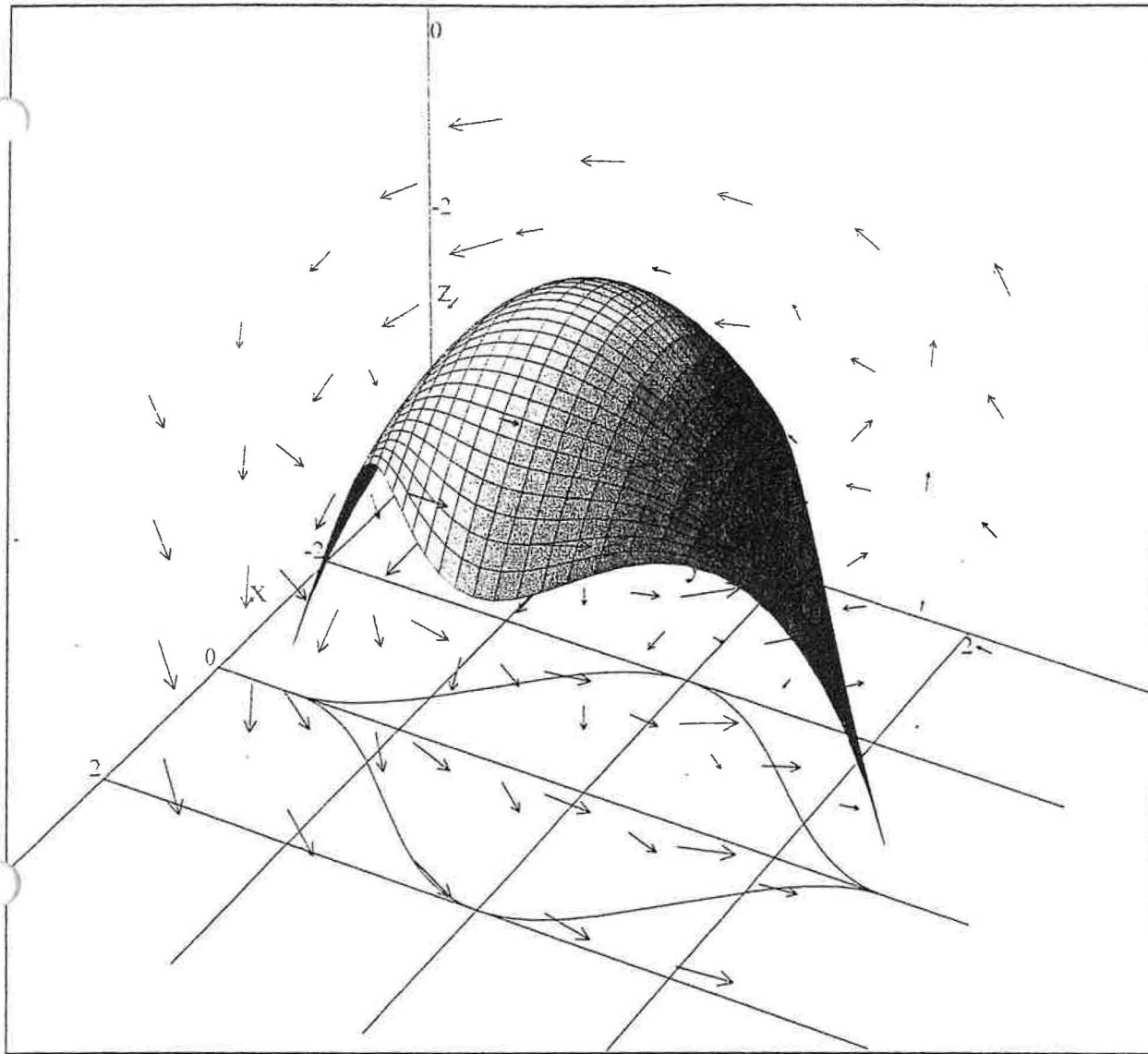

Copyright July 2000 by Scott Guth  
Mt. San Antonio College

## Vertically Simple Surfaces with Vector Fields

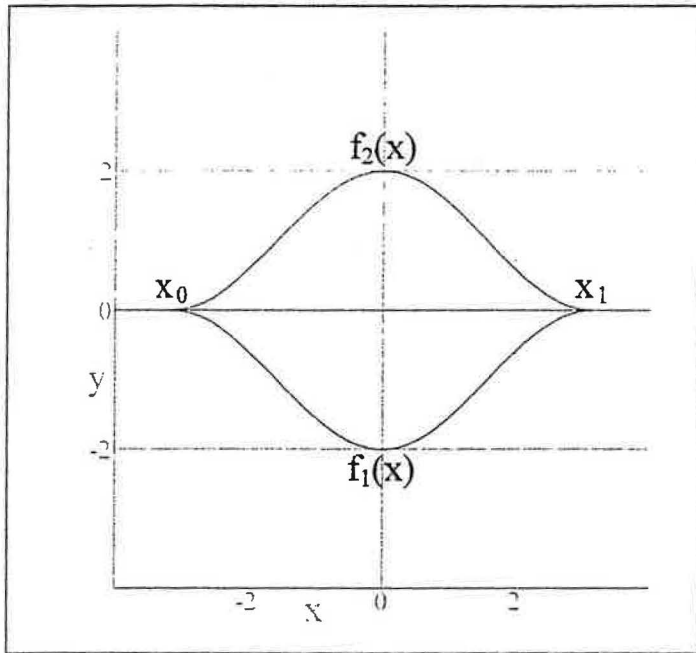

Please enter your surface  $f(x, y)$  below.

$$f(x, y) = \frac{1 - x^2 - y^2}{2}$$

Please enter the bottom and top boundaries of the vertically simple region.

$f_1(x)$  is the bottom boundary of the region.  $f_2(x)$  is the top boundary.

$$f_1(x) = -\cos(x) - 1 \quad f_2(x) = \cos(x) + 1$$

Next, enter the limits on  $x$  below.

$$x_0 = -\pi \quad x_1 = \pi$$

Enter your vector field below. Separate the  $x$ ,  $y$ , and  $z$  components by commas.

$$F(x, y, z) = \left( -y, x, \frac{z}{2} \right)$$

Click here \* when finished.

We now proceed to compute the flux of  $F$  through  $z = f(x, y)$ . First, we compute  $N \, dS$ , the unit normal times the differential of surface area.

$$N \, dS = \left( -\frac{\partial}{\partial x} f[x, y], -\frac{\partial}{\partial y} f[x, y], 1 \right) dS$$

$$N \, dS = (x, y, 1) dS$$

Next we evaluate the surface integral for flux:

$$\text{Flux} = \int F \cdot N \, dS$$

$$\text{Flux} = \int_{x_0}^{x_1} \left( \int_{f_1[x]}^{f_2[x]} [F\{x, y, z\} \cdot N] \, dy \right) dx$$

$$\text{Flux} = \int_{-\pi}^{\pi} \left( \int_{-\cos[x]-1}^{\cos[x]+1} [F\{x, y, f(x, y)\} \cdot \{x, y, 1\}] \, dy \right) dx$$

$$\text{Flux} = \int_{-\pi}^{\pi} \left( \int_{-\cos[x]-1}^{\cos[x]+1} [F\{x, y, \frac{1}{2}(-x^2 - y^2 + 1)\} \cdot \{x, y, 1\}] \, dy \right) dx$$

$$\text{Flux} = \int_{-\pi}^{\pi} \left( \int_{-\cos[x]-1}^{\cos[x]+1} [\{-y, x, \frac{1}{2}(\frac{1}{2}[-x^2 - y^2 + 1])\} \cdot \{x, y, 1\}] \, dy \right) dx$$

$$\text{Flux} = \int_{-\pi}^{\pi} \left( \int_{-\cos[x]-1}^{\cos[x]+1} [-\frac{1}{4}x^2 - \frac{1}{4}y^2 + \frac{1}{4}] \, dy \right) dx$$

$$\text{Flux} = -\frac{1}{3}\pi^3 + \frac{13}{6}\pi$$

$$\text{Flux} = -3.5286$$

Finally we plot the surface and the vector field. Please enter min and max values of x, y, and z. These values define the viewing window. If your surface does not fit in the window, change the limits until it does.

$$x_{\min} = -4 \quad x_{\max} = 4$$

$$y_{\min} = -4 \quad y_{\max} = 4$$

$$z_{\min} = -5 \quad z_{\max} = 1$$

Click here \* when finished.

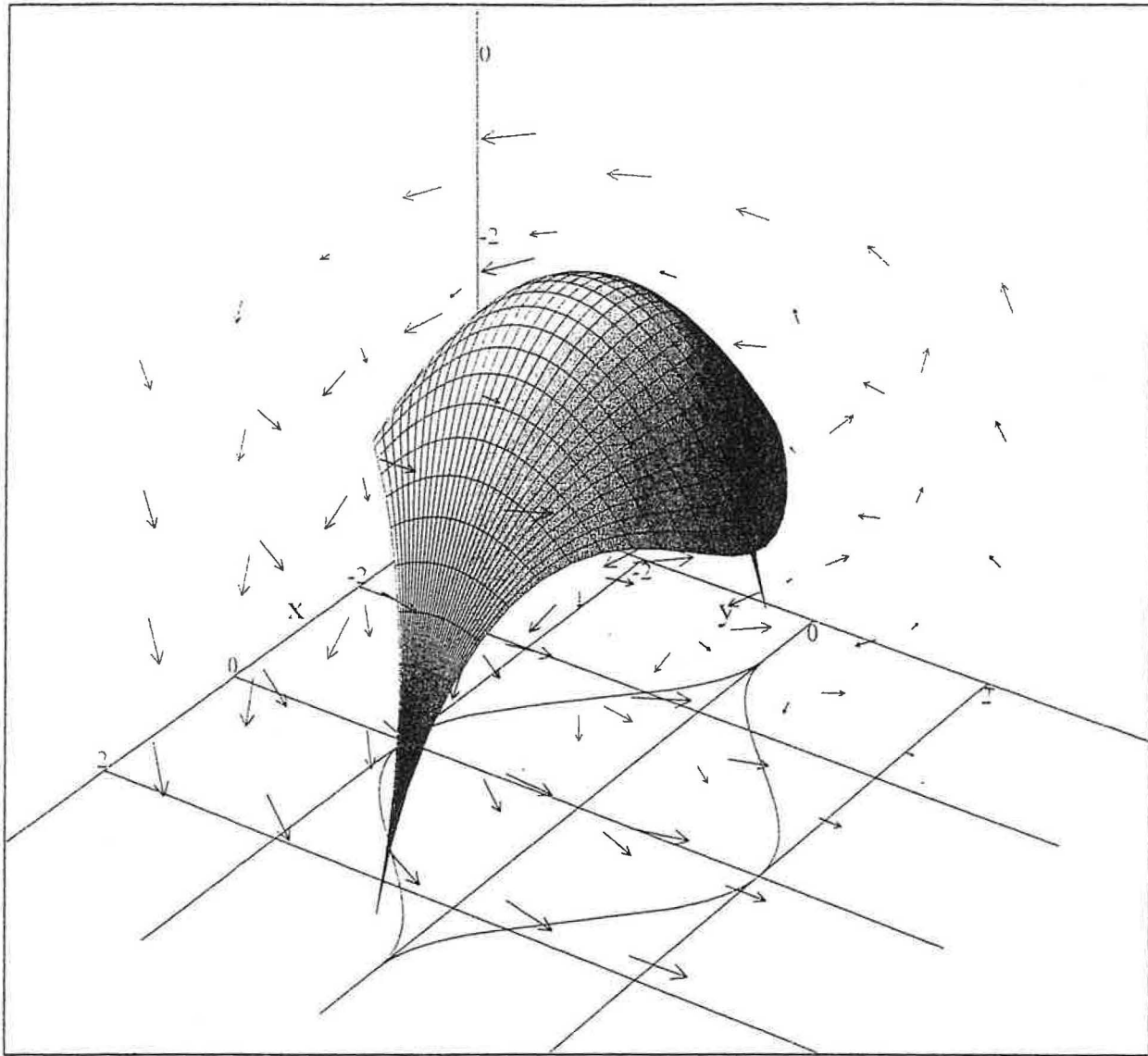

Copyright July 2000 by Scott Guth  
Mt. San Antonio College

### 3D Parametric Surfaces with Vector Fields

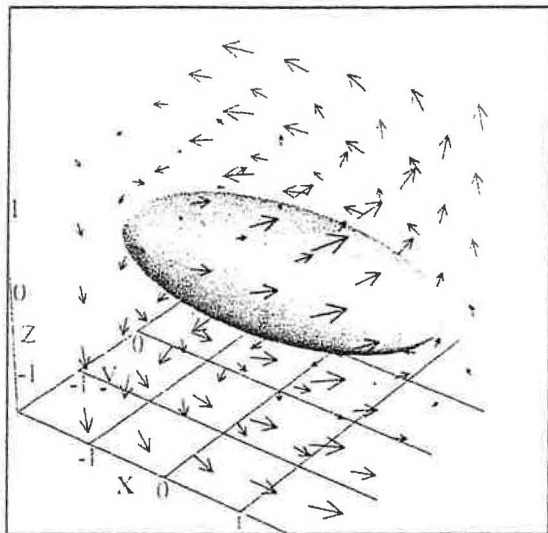

Please enter your parametric surface below as a function of  $u$  and  $v$ . Separate the  $x$ ,  $y$ , and  $z$  components by commas.

$$r(u, v) = \left( 2 \sin[v] \cos[u], \sin[v] \sin[u], \frac{\cos[v]}{2} \right)$$

Next enter your vector field:

$$F(x, y, z) = \left( -y, x, \frac{z}{2} \right)$$

Click here \* when done.

Now we need limits on the parameters  $u$  and  $v$ .

$$\begin{aligned} v_{\min} &= 0 & v_{\max} &= \pi \\ u_{\min} &= 0 & u_{\max} &= 2\pi \end{aligned}$$

Finally we need limits on  $x$ ,  $y$ , and  $z$ . These are used only to define the size of the window. If your surface doesn't fit in the plot window, widen the range on these limits.

$$\begin{aligned} x_{\min} &= -2 & x_{\max} &= 2 \\ y_{\min} &= -2 & y_{\max} &= 2 \\ z_{\min} &= -1.5 & z_{\max} &= 1.5 \end{aligned}$$

Click here \* to draw your graph.

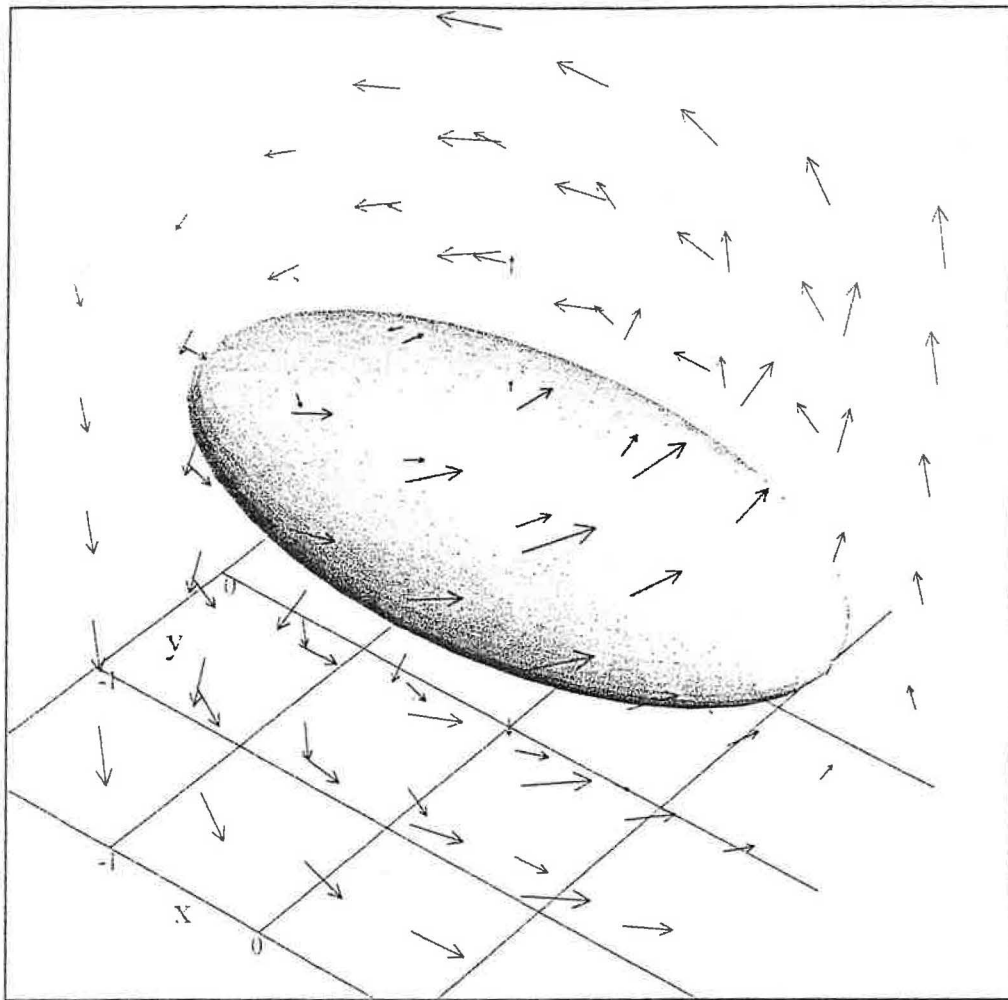

Copyright July 2000 by Scott Guth  
Mt. San Antonio College

## 3D Parametric Surfaces with Vector Fields & Flux

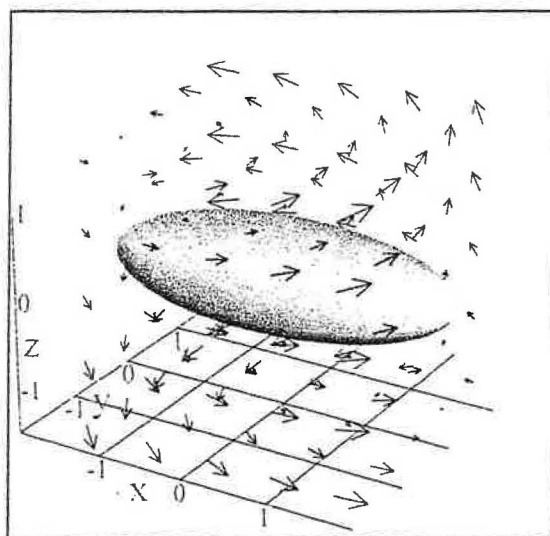

Please enter your parametric surface below as a function of  $u$  and  $v$ . Separate the  $x$ ,  $y$ , and  $z$  components by commas.

$r(u, v) = \left( 2 \sin[v] \cos[u], \sin[v] \sin[u], \frac{\cos[v]}{2} \right)$

Click here \* when done.

Here we compute  $N \, dS$ , the normal vector times the surface differential.

$$N \, dS = \left( \frac{\partial}{\partial u} r[u, v] \times \frac{\partial}{\partial v} r[u, v] \right) du \, dv$$

Next, please enter your vector field:

$$F(x, y, z) = \left( -y, x, \frac{z}{2} \right)$$

Now we need limits on the parameters  $u$  and  $v$ .

$$\begin{aligned} v_{\min} &= 0 & v_{\max} &= \pi \\ u_{\min} &= 0 & u_{\max} &= 2\pi \end{aligned}$$

Click here \* when done.

Here we compute the flux of  $F$  through  $N$ .



Flux =  $\int F \cdot N \, dS$

Flux =  $\int_{v_{\min}}^{v_{\max}} \left( \int_{u_{\min}}^{u_{\max}} [F\{x(u, v), y(u, v), z(u, v)\} \cdot N] \, du \right) \, dv$

Flux =  $-\frac{2}{3}\pi$

Finally, to plot the surface, we need limits on x, y, and z. These are used only to define the size of the window. If your surface doesn't fit in the plot window, widen the range on these limits.

xmin = -2      xmax = 2

ymin = -2      ymax = 2

zmin = -1.5      zmax = 1.5

Click here \* to draw your graph.

